



EXCALIBUR WATER SYSTEMS

COMMERCIAL WATER SOFTENER

SYSTEM DESIGN DATA & SPECIFICATIONS

Model: EWS S130
Water Softener 1.0" Simplex 30,000 Capacity

Water Softener Operating Parameters

Minimum Flow Rate, gpm	: 0.9
Critical Flow Rate, gpm	: 3.5
Service Flow Rate, gpm	: 5.0
Flow Rate 15psi ΔP, gpm	: 14.0
Flow Rate 25psi ΔP, gpm	: 21.0
Backwash Flow Rate, gpm	: 2.2
Capacity @15lbs/ft ³ , kgr	: 30.0
Capacity @10lbs/ft ³ , kgr	: 27.0
Capacity @6lbs/ft ³ , kgr	: 20.0
Capacity Max System, kgr	: 30.0
Salt Usage @ 15lbs/ft ³ , lbs	: 15.0
Salt Usage @ 10lbs/ft ³ , lbs	: 10.0
Salt Usage @ 6lbs/ft ³ , lbs	: 6.0
Resin Qty, ft ³	: 1.0
#20 Gravel Qty, lbs	: 12.0
Distributor Size, in	: 1.05
Drain Line Size, in	: 0.75
Brine Line Size, in	: 0.375

Miscellaneous Design Data

Mineral Tank Size, in.	: 9x48
Freeboard, in.	: 15.0
Bed Depth, in	: 27.0
Brine Tank Size, in.	: 18x33
Max. Salt Load, lbs.	: 350 (Dry)
Total Regeneration Time, min.	: 87
Operating Pressure, psi	: 40-110
Operating Temperature, ° F	: 40-110
Shipping Weight, lbs.	: 115
Operating Weight, lbs.	: 560
Space Req'd in, L x W x H	: 39x29x63

Electrical Specifications

Supply Voltage	: 120VAC
Supply Frequency	: 60 Hz
Output Voltage	: 15VDC
Output Current:	: 500 mA

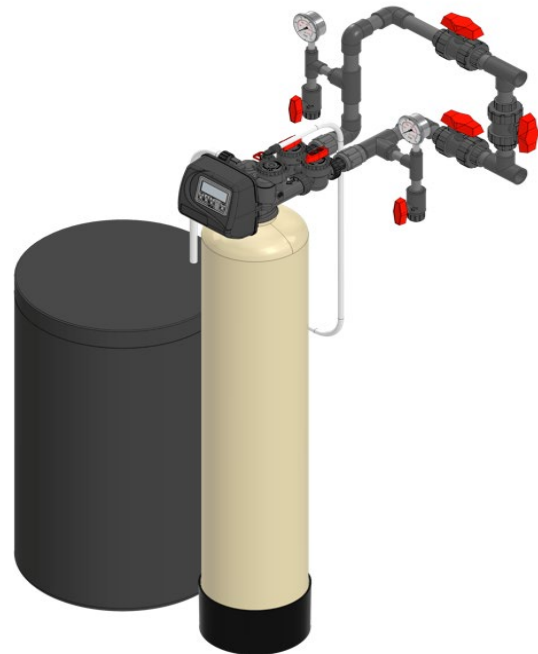
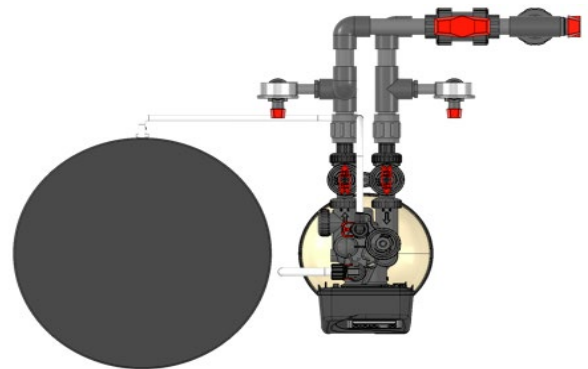

** Pipe and fittings shown not in scope*