



Quality through innovation

2" QC DUPLEX ALTERNATING CHEMICAL REMOVAL INSTALLATION AND USER GUIDE

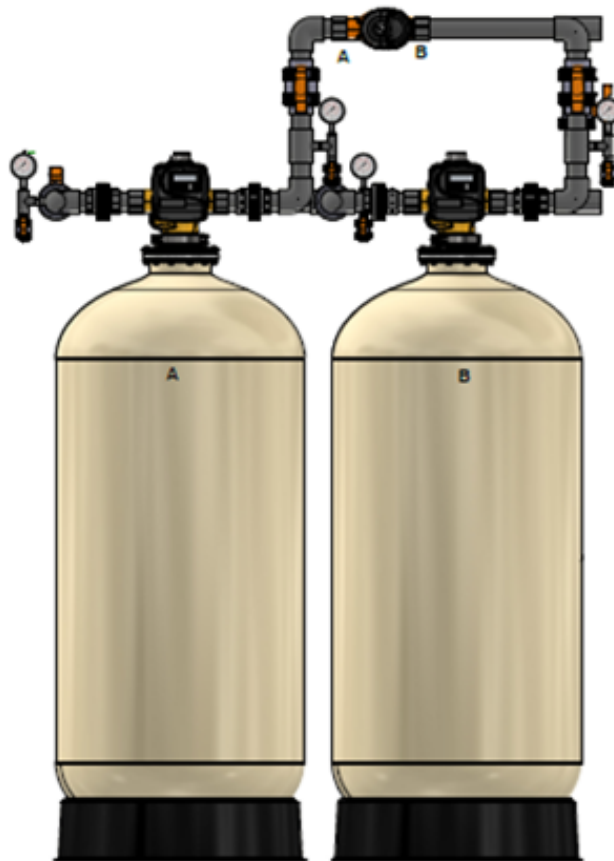

TABLE OF CONTENTS

- 1) Installation 3
 - 1.1) Pre-installation instructions..... 3
 - 1.2) General Installation and Service Warnings..... 3
 - 1.3) Site Requirements..... 3
 - 1.4) Installation Drawing..... 4
 - 1.5) Piping and Instrumentation Drawing..... 5
 - 1.6) System Drawing 6
 - 1.7) Plumbing 6
 - 1.8) Drain Line 7
 - 1.9) 3-Way Bypass Valve 7
 - 1.10) Loading Instructions..... 9
 - 1.11) Start Up Instructions 10
- 2) Programming 11
 - 2.1) Regeneration and Error Screens 11
 - 2.2) Button Operation..... 11
 - 2.3) User Displays..... 12
 - 2.4) Setting Time of Day..... 13
 - 2.5) Configuration Settings 13
 - 2.6) Installer Display Settings..... 14
 - 2.7) Filter System Setup 15
 - 2.8) Diagnostics 16
- 3) Specifications and Programming 18
 - 3.1) Specifications 18
 - 3.2) Programming 18
- 4) Control Valve..... 19
 - 4.1) Control Valve Specifications 19
 - 4.2) Control Valve Drawing 21
 - 4.3) Flow Diagrams..... 22
 - 4.4) Components of Control Valve..... 24
- 5) Quick Reference Guide 29
- 6) Service Instructions..... 30
 - 6.1) Front Cover Removal 30

- 6.2) PC Board Removal..... 31
- 6.3) Drive Bracket Removal..... 32
- 6.4) Backplate Removal..... 33
- 6.5) Drive Cap Removal..... 34
- 6.6) Stack Assembly..... 35
- 7) Troubleshooting..... 35
 - 7.1) Possible Error Codes 35
 - 7.2) Troubleshooting Procedures..... 36
- 8) 5 Year Warranty..... 39

1) INSTALLATION

1.1) Pre-installation instructions

The cycle times, sequence of cycles and chemical removal capacity are preset to default by Excalibur. The installer must change the values according to the water test results, day override and time of regeneration. Set time of day, read normal operating displays, read power loss and error displays.

WATER TEST

Hardness	_____	gpg
Iron	_____	ppm
pH	_____	number
*Nitrates	_____	ppm
Manganese	_____	ppm
Sulphur	_____	yes/no
Total Dissolved Solids	_____	

1.2) General Installation and Service Warnings

- The filter is designed so that it can be installed easily with minor plumbing changes on previous plumbing.
- The piping must be clamped properly and the weight of the plumbing must not be on the filter.
- Do not use any kind of lubricant including silicone. A silicone based lubricant can be only used on O- Rings but not necessary.
- The nuts and caps can be fastened and unfastened by hand or the plastic service wrench. Do not use pipe wrench to tighten the caps and nuts.

1.3) Site Requirements

- Water Pressure: - 40-110 psi
- Water Temperature: - 40-110°F (4.4-43°C)
- Electrical- 115/120 V, 60Hz Uninterrupted Outlet
- Current required is 0.5 Amperes
- The plug-in transformer is for dry locations only
- The tank should be on a firm level surface

1.4) Installation Drawing

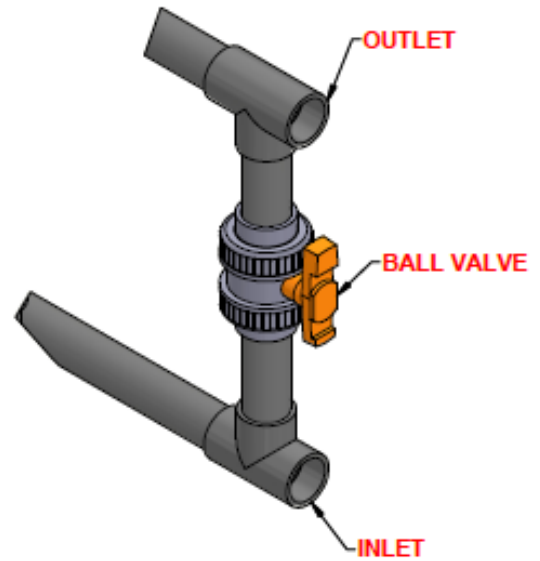
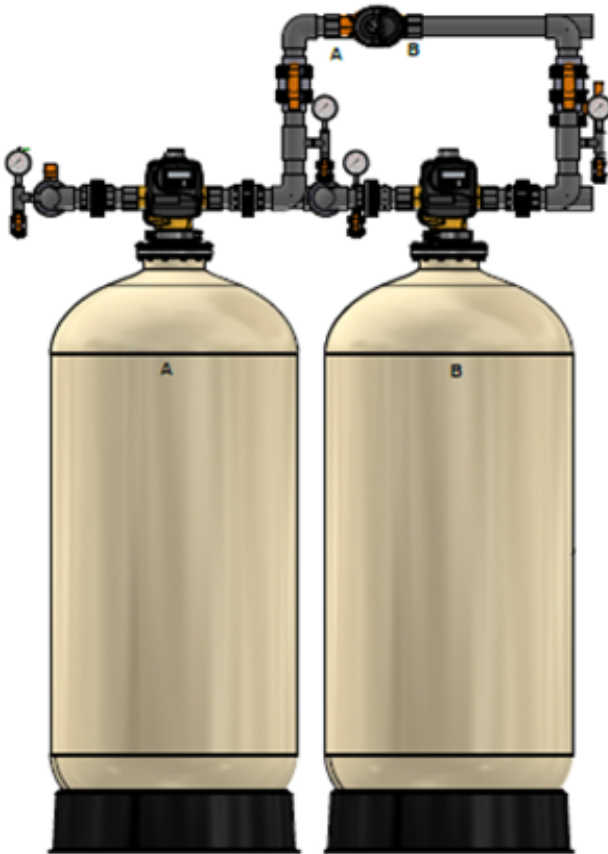
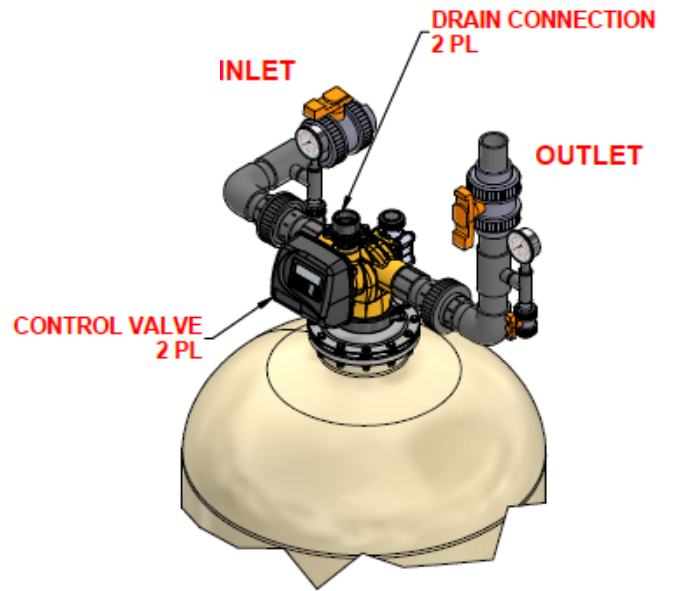
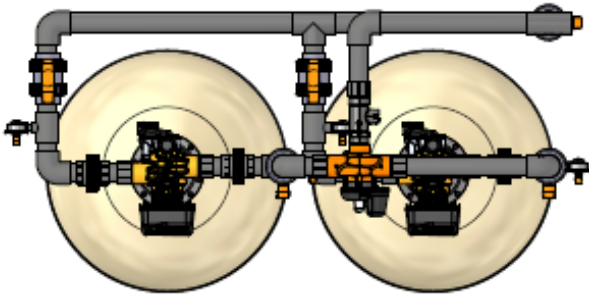

1.5) Piping and Instrumentation Drawing

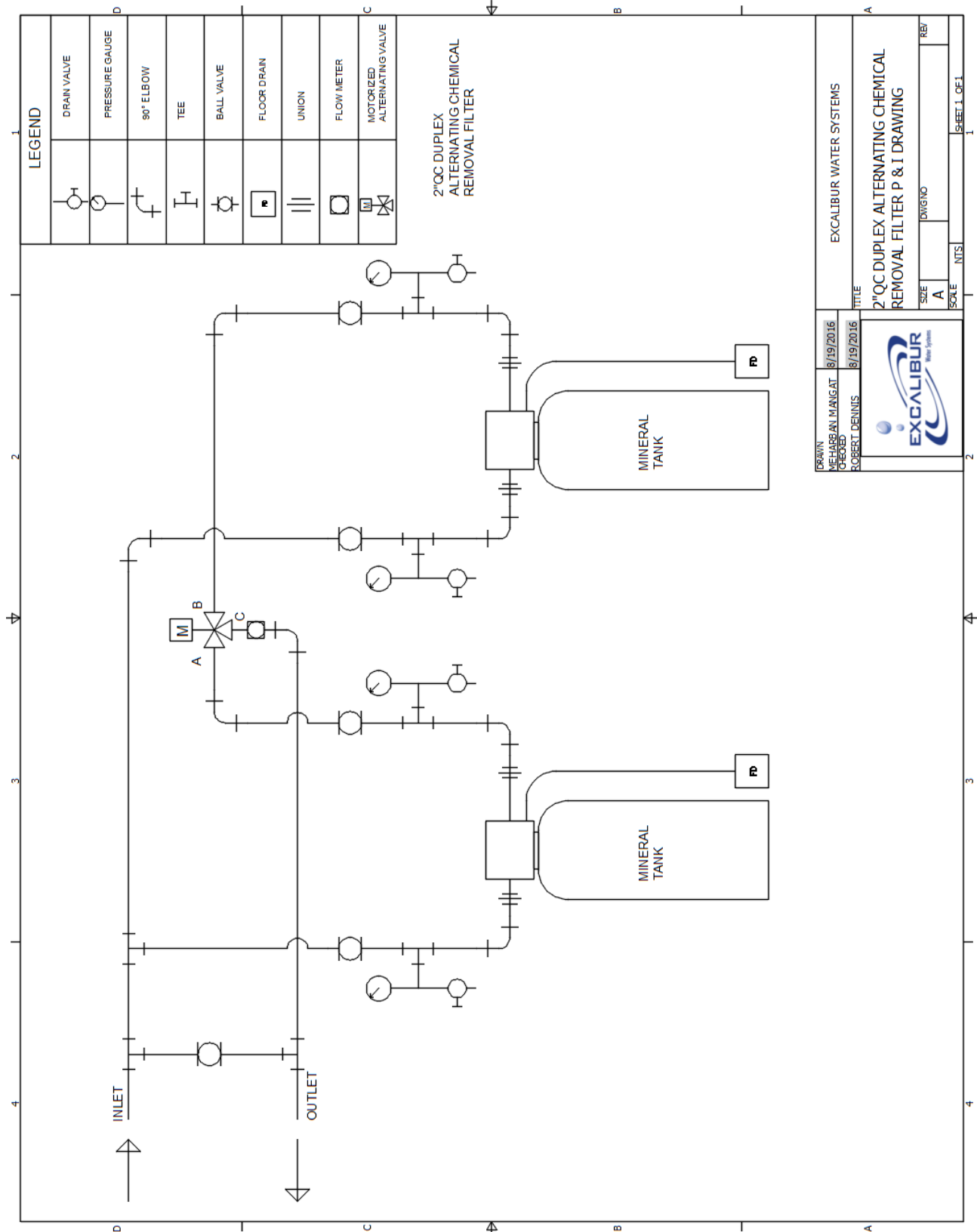

LEGEND	
	DRAIN VALVE
	PRESSURE GAUGE
	90° ELBOW
	TEE
	BALL VALVE
	FLOOR DRAIN
	UNION
	FLOW METER
	MOTORIZED ALTERNATING VALVE

2"QC DUPLEX ALTERNATING CHEMICAL REMOVAL FILTER

DRAWN MEHARJAN MANGAT 8/19/2016	CHECKED ROBERT DENNIS 8/19/2016	TITLE EXCALIBUR WATER SYSTEMS
		2"QC DUPLEX ALTERNATING CHEMICAL REMOVAL FILTER P & I DRAWING SIZE: A DWG NO: _____ SCALE: _____ NTS: _____ REF: _____ SHEET 1 OF 1

1.6) System Drawing

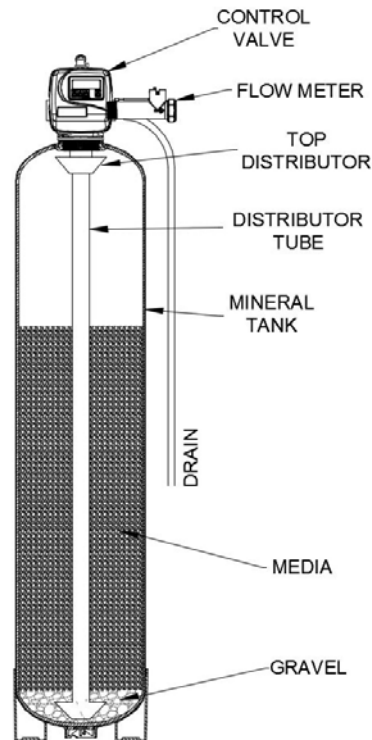

1.7) Plumbing

- The 3-way bypass valve must be installed.
- The filter must be close to drain as much as possible.
- The primer, solder or solder flux must not get on the O-rings.
- After soldering the lines must be cooled before installing the O-Rings, nuts and caps.
- If the electrical system is grounded to the plumbing than copper strap must be connected between inlet and outlet as shown in figure above.
- The plumbing must be done by following the local plumbing codes.
- The unit including the drain must be located in a room temperature above 33° F.
- Never let the vacuum occur in tank this may cause implosion and leakage. If vacuum occurrence is expected than vacuum breaker must be installed in line.

1.8) Drain Line

- The size of the drain line must be according to the model specifications.
- Leave minimum of 6" gap between flow control fitting and solder joints. The gap less than this can damage the flow control.
- Use 1.5" or 2" tubing for drain line according to the specifications.
- If the drain line is elevated and then emptied into the drain below the level the of control valve the 7" loop should make at the end of drain line.
- The air gap between the drain and the end of the drain line must be twice the diameter of the tube.
- The pipe must be clamped at the end to secure the line.

1.9) 3-Way Bypass Valve

The shut off valves must be installed at inlet and outlet of control valve. The bypass pipe including the ball valve must also be installed to bypass the unfiltered water to supply.

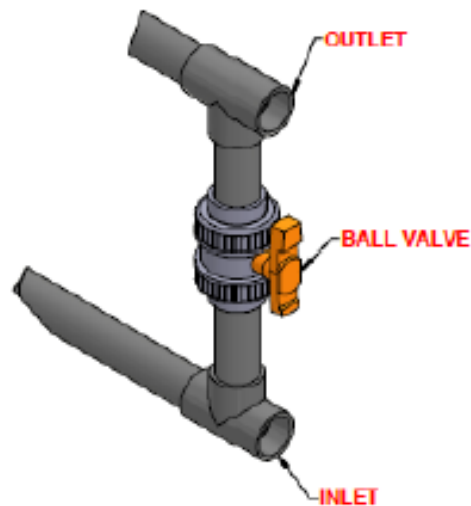

FILTER INSTALLATION AND USER GUIDE

NORMAL POSITION

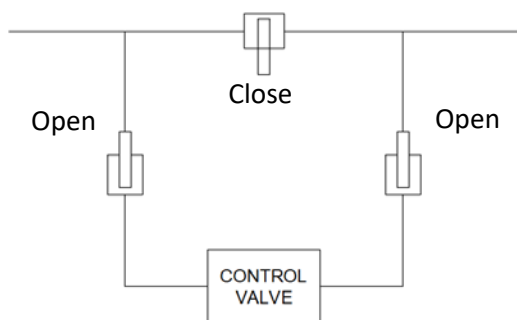

Normal Position: - Fully close the bypass valve and fully open both valves at inlet and outlet of the control valve. The supply water (unfiltered) enters in and filtered water exits.

BYPASS POSITION

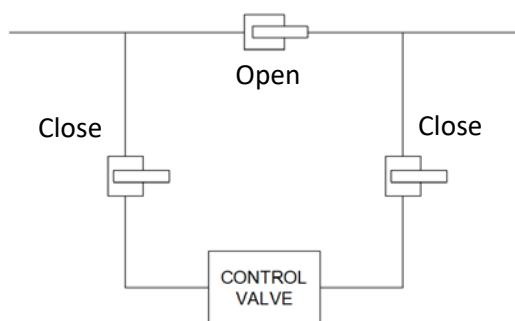

Bypass Position: - The inlet and outlet valves at the control valve must be fully closed but the bypass valve must be fully open. The supply water enters and bypass the control valve and exits unfiltered as supply water.

DIAGNOSTIC POSITION

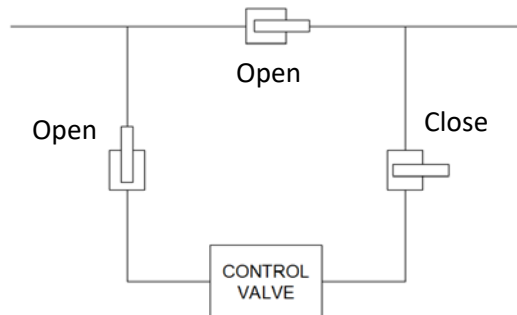

Diagnostic Position: - The outlet valve must be fully closed but bypass valve and inlet valve must be fully open. The unfiltered water will be supplied but in this position technician will be able to draw a brine and perform other tests.

SHUT OFF POSITION

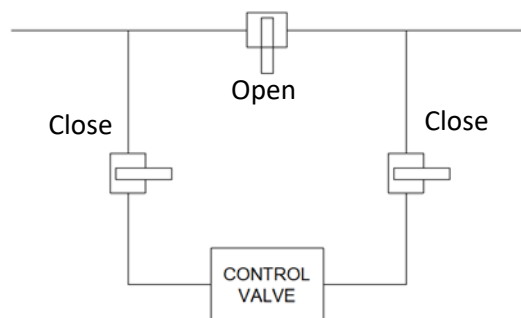

Shut Off Position: - All three valves must be at fully closed position. The water supply is shut down means there will be no flow at the outlet.

1.10) Loading Instructions

Step 1: Check the product upon arrival and remove from box packaging checking for any shipping damage or shortages that must be reported to Excalibur Water Systems immediately for confirmation.

Step 2: Insert distributor(s) inside of media mineral tank(s) so it is positioned properly in the bottom centre groove. If not already sized properly cut the top of the distributor pipe $\frac{1}{2}$ - $\frac{3}{4}$ " above top of tank opening and clean off and excess PVC materials with grit cloth.

Step 3: Plug the top inlet opening of the distributor (Hub & Lateral) or bottom stack with a clean cloth, rag, or tape to prevent any gravel or resin from entering into the distributor tube.

Step 4: Load the gravel under bedding onto the mineral tank using a funnel or some sort of loading device. If multiple layers of gravel with different sizes being utilized always load the largest gravel size in diameter to the smallest last.

Step 5: Load the filtration media also using a funnel or some sort of loading device until all resin is inside of mineral tank.

Step 6: Remove top opening cover of the distributor carefully not to move or disturb the distributor tube not allowing any debris or materials to get inside of the now loaded filter(s).

Step 7: Thread on control valves onto top opening tanks be sure to check and verify that the O-ring on the bottom base of the control valve is present and properly lubricated with silicone. Tighten control valve(s) clockwise until you have reached the end of the thread and have secured a water tight seal. (If control valves that utilize quick connect collars thread the collars the same into the tanks then attach control valves).

Step 8: Precede now with the unit(s) in their proper installation locations to run piping and materials for all inlet, outlet, and drain connections properly with isolation valves and test ports for future water tests. Also unions should be included in installation materials for easy future servicing of the control valves when necessary on all inlet, outlet, and drain lines.

1.11) Start Up Instructions

- Keep the 3-way bypass valves in bypass position by keeping inlet and outlet valves fully closed and bypass valve fully open. Now the unfiltered water is being supplied. Open the faucet downstream of filter and keep it open until water comes clear out of it. The initial water can be dirty because of installation debris. Now inspect the leaks in plumbing.
- Press and hold the “REGEN” button down for 5 seconds to start manual regeneration. The drive motor will start the backwash cycle and countdown time begins. Turn the inlet valve handles halfway into the direction of service position. Once the steady water flows out of drain then fully open the inlet and outlet valves and fully close the bypass valve.
- Press REGEN button to advance the regeneration to rinse cycle. The water will come through the drain. Allow this process until water coming through the drain becomes clear.

2) PROGRAMMING

2.1) Regeneration and Error Screens



Regen Screen

Displays the time remaining in the current cycle. Pressing REGEN advances to the next cycle.

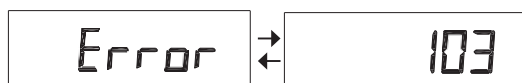

Error Screen

Alternated flashing Error and error code every 3 seconds. Clear by disconnecting the power supply at the PC board and reconnecting, or press NEXT and REGEN simultaneously for 3 seconds.

2.2) Button Operation



Scrolls to the next display.



- Pressing once and releasing will schedule a regeneration at the preset delayed regeneration time.
- Pressing again and releasing will cancel the regeneration.
- Pressing and holding for 3 seconds will initiate an immediate regeneration
- Pressing while in regeneration will advance to the next cycle.
- Pressing in the program levels will go backwards to the previous screen



Change Variable being displayed.



Key sequence to lock and unlock program settings



Holding for 3 seconds initiates a control reset. The software version is displayed and the piston returns to the home/service position, resynchronizing the valve.

2.3) User Displays

When the system is operating, one of five displays may be shown. Pressing NEXT will alternate between the displays shown below.

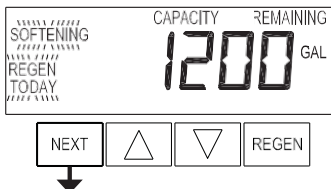

User 1

Typical user display. Shows volume remaining to regeneration. This screen will not be viewed if the control is set for time-clock operation.

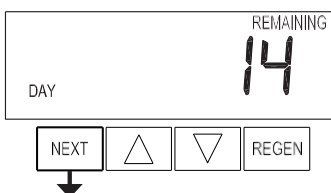

User 2

Displays number of days to next regeneration.

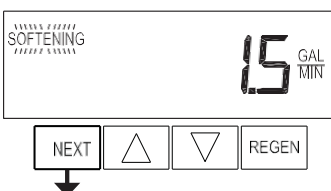

User 3

Flow Rate.

Displays present flow rate.

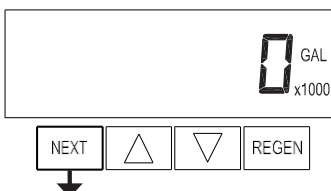

User 4

Displays total volume in gallons since last reset. If a meter is not used this display will be shown but 0 will be displayed.

PRESS ▼ FOR 3 SECONDS TO RESET TO 0.



User 5

Shows current time.

2.4) Setting Time of Day

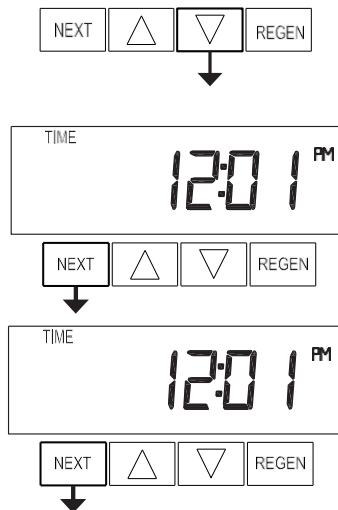

- Push NEXT button until time of day screen is displayed.
- Press and hold ▼ until SET TIME is displayed and the hour flashes once.
- Press ▲ or ▼ until the correct hour is displayed. Then press NEXT.
- The minutes will flash. Press ▲ or ▼ until the correct minute is displayed. Press NEXT to return to the User Displays.

If a power outage lasts less than 8 hours and the time of day flashes on and off, the battery should be replaced and the time should be reset.

2.5) Configuration Settings

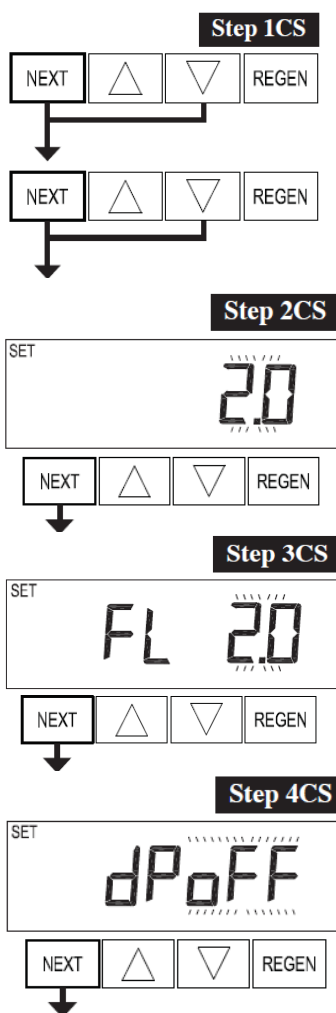

Step 1CS – Press NEXT and ▼ simultaneously for 5 seconds and release. Press NEXT and ▼ simultaneously for 5 seconds and release. If the screen in Step 2CS does not appear, the lock on the valve is activated. To unlock, press ▼, NEXT, ▲ and REGEN in sequence, then press NEXT and ▼ simultaneously for 5 seconds and release. Press NEXT and ▼ simultaneously for 5 seconds and release.

Step 2CS – Use ▲ or ▼ to select **2.0** for 2.0" valve. Press NEXT to go to Step 3CS. Press REGEN to exit Configuration Settings.

Step 3CS – Use ▲ or ▼ to select "2.0" meter size. Press NEXT to go to Step 4CS. Press REGEN to return to previous step.

Step 4CS – Select dP OFF - outside regeneration signal feature not used, by using ▲ or ▼ buttons.

Press NEXT to go to Step 5CS. Press REGEN to return to previous step.

Step 5CS

RETURN TO NORMAL SCREENS

Step 5CS – Select feature “ALT” using ▲ or ▼ buttons for Duplex filters.

Press NEXT to exit to Display Screens.
Press REGEN to return to previous step.

2.6) Installer Display Settings

Step 1I

Step 1I - To enter Installer Display press NEXT and ▲ simultaneously for about 5 seconds and release.

Step 2I

Step 2I – Day Override: Set “4” maximum number of days between regenerations using ▲ or ▼:

Press NEXT to go to step 4I. Press REGEN to return to previous step.

Step 3I

Step 3I – Next Regeneration Time (hour): Set the hour of day for regeneration using ▲ or ▼. The default time is 2:00.

Press NEXT to go to step 5I. Press REGEN to return to previous step.

Step 4I

Step 4I – Next Regeneration Time (minutes): Set the minutes of day for regeneration using ▲ or ▼.

Press NEXT to exit Installer Display Settings. Press REGEN to return to previous step.

Exit Installer Display Settings

2.7) Filter System Setup



Step 1F - Press NEXT and ▼ simultaneously for 5 seconds and release.



Step 2F – Choose “FILTERING BACKWASH” using ▲ or ▼. Press NEXT to go to Step 3S. Press REGEN to exit OEM Filter System Setup.



Step 3F – Select the 10-minute time for the first/backwash cycle using ▲ or ▼. Press NEXT to go to Step 4F. Press REGEN to return to previous step.



Step 4F – Select the 8-minute time for second/fast rinse cycle using ▲ or ▼. Press NEXT to go to step 5F.



Step 5F – Set the regeneration trigger using ▲ or ▼ to adjust the number of gallons as per specifications of filter model.

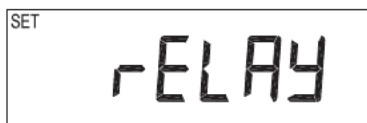

Step 6S – Select relay operation “oFF” using ▲ or ▼ buttons. Press NEXT to exit filter system setup.



2.8) Diagnostics

Step 1D

Step 1D - Press ▲ and ▼ simultaneously for 5 seconds and release. If screen in Step 2D does not appear the lock on the valve is activated. To unlock press ▼, NEXT, ▲, REGEN in sequence, then press ▲ and ▼ simultaneously for 5 seconds and release.

Step 2D

Step 2D – Software Version. Press NEXT to go to Step 3D. Press REGEN to exit Diagnostics.

**Step 3D**

Step 3D – Volume, total used since start-up: This display shows the total gallons filtered since startup. This display will equal zero if a water meter is not installed. Press the NEXT button to go to Step 4D. Press REGEN to return to previous step.

**Step 4D**

Step 4D – Days, total since start-up: This display shows the total days since startup. Press the NEXT button to go to Step 5D. Press REGEN to return to previous step.

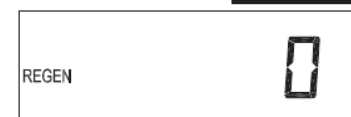
**Step 5D**

Step 5D – Regenerations, total number since start-up: This display shows the total number of regenerations that have occurred since startup. Press the NEXT button to go to Step 6D. Press REGEN to return to previous step.

**Step 6D**

Step 6D – Error Log: This display shows a history of the last 10 errors generated by the control during operation. Press ▲ or ▼ to view each recorded error.

Press NEXT to go to Step 7D. Press REGEN to return to previous step.

**Step 7D**

Step 7D – Days, since last regeneration: This display shows the days since the last regeneration occurred.

Press NEXT to go to Step 8D. Press REGEN to return to previous step.



Step 8D

Step 8D – Volume, since last regeneration: This display shows the volume of water that has been filtered since the last regeneration. This display will equal zero when a water meter is not installed. Press NEXT to go to Step 9D. Press REGEN to return to previous step.

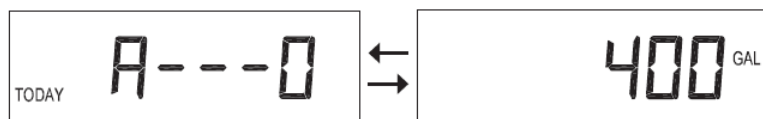
Step 9D

Step 9D – Volume, reserve capacity used for last 7 days. This display shows day 0 (for today) and flashes the reserve capacity. Pressing ▲ will show day 1 (which would be yesterday) and flashes the reserve capacity used. Pressing ▲ again will show day 2 (the day before yesterday) and the reserve capacity. Keep pressing ▲ to show the capacity for days 3, 4, 5 and 6. ▼ can be pressed to move backwards in the day series.

Press NEXT at any time to go to Step 10D. Press REGEN to return to previous step.

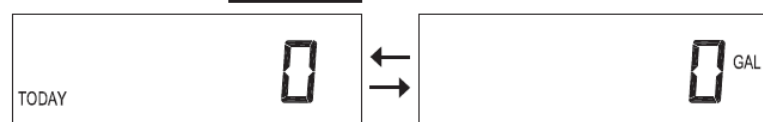
Step 10D

Step 10D – Volume, 63-day usage history: This display shows day 0 (for today) and flashes the volume of water filtered today. Pressing ▲ will show day 1 (which would be yesterday) and flashes the volume of water filtered on that day. Continue to press ▲ to show the maximum volume of water filtered for the last 63 days. If a regeneration occurred on the day the word “REGEN” will also be displayed. This display will show dashes if a water meter is not installed.

Press NEXT to exit Diagnostics. Press REGEN to return to previous step.

3) SPECIFICATIONS AND PROGRAMMING

3.1) Specifications

Model	Total Media (ft ³)	Tank Size (Dia x Height)	Flow Rate (GPM)					Backwash
			Minimum	Chloramine Removal	TOC Removal	Chlorine Removal		
EWS FD2MQCCS4	4.0	16x65	1.6	3.0	4.0	12.0		13.0
EWS FD2MQCCS5	5.0	18x65	2.0	3.8	5.0	15.0		17.0
EWS FD2MQCCS6	6.0	21x62	2.4	4.5	6.0	18.0		25.0
EWS FD2MQCCS8	8.0	24x72	3.2	6.0	8.0	24.0		31.5
EWS FD2MQCCS12	12.0	30x72	4.8	9.0	12.0	36.0		47.5
EWS FD2MQCCS18	18.0	36x72	7.2	13.5	18.0	54.0		70.0

3.2) Programming

Configuration Settings				
Step #	2CS	3CS	4CS	5CS
Option	2.0	2.0	oFF	oFF

OEM Filter System Setup					
Step #	2S	3S	4S	5S	6S
Option	Filtering Backwash	10	8	Off	Off

4) CONTROL VALVE

4.1) Control Valve Specifications



- 2" top mount or side mount control valve suited for commercial/Industrial applications
- Epoxy coated lead free brass valve body*
- Economical stainless steel optional meter assembly
- Service flow rate of 125 gpm, backwash 85 gpm
- Solid state microprocessor with easy access front panel settings
- Front panel display for time of day, days until next regeneration, volume remaining, current flow rate and total volume used (Totalizer)
- Four methods to initiate regeneration; meter immediate, meter delayed, time clock delayed or pressure differential
- Optional double backwash feature offers optimum regeneration, cleaning ability and efficiency
- Fully adjustable cycle times with 6-cycle control delivers controlled backwash, downflow brining or upflow brining, slow rinse, second backwash, fast rinse, refill and downflow service
- Coin Cell Lithium battery back-up with an 8 hour carry over
- 12-volt output AC Adapter provides safe and easy installation
- Post treated water regenerant refill
- Reliable and proven DC drive
- Patented one piece expanding seal spacer stack assembly U.S. Patent 6,402,944
- Patented linearly reciprocating piston operation U.S. Patent 6,444,127



Optional Side Mount Adapter

Minimum/Maximum Operating Pressures	20 psi (138 kPa) -125 psi (862 kPa)
Minimum/Maximum Operating Temperatures	40°F (4°C) - 110°F (43°C)
Power Adapter: Supply Voltage Supply Frequency Output Voltage Output Current	110 V AC 60 Hz 12 V AC 500 mA
No user serviceable parts are on the PC board, the motor, or the Power adapter. The means of disconnection from the main power supply is by unplugging the Power adapter from the wall.	
Service flow rate	125 gpm (473 lpm, 28.4 m ³ /h) @ 15 psig (103kPa) drop
Backwash flow rate	85 gpm (322 lpm, 19.3 m ³ /h) @ 25 psig (172kPa) drop
CV Service	32.3
CV Backwash	17.0
Meter: Accuracy Flow Range	± 5% 1.5 – 150 gpm (5.7 – 568 lpm)
Regenerant Refill Rate	Variable - Shipped from Factory with 2.2 gpm (8.33 lpm)
Inlet / Outlet	2" Female NPT or BSPT
Drain Line	1.5" Female NPT
Distributor Tube Opening	Female NPT Inlet & Outlet 2.375" OD (2.0" NPS)
Tank Connection	4"-8UN, 6" Flange, Side Mount
Shipping Weight	2" Valve quick connect and Meter: 30 lbs (14 kg)
PC Board Memory	Nonvolatile EEPROM (electrically erasable programmable read only memory)
Compatible with the following typical concentrations of regenerants/chemicals	Sodium chloride, potassium chloride, potassium permanganate, sodium bisulfite, chlorine and chloramines

4.2) Control Valve Drawing

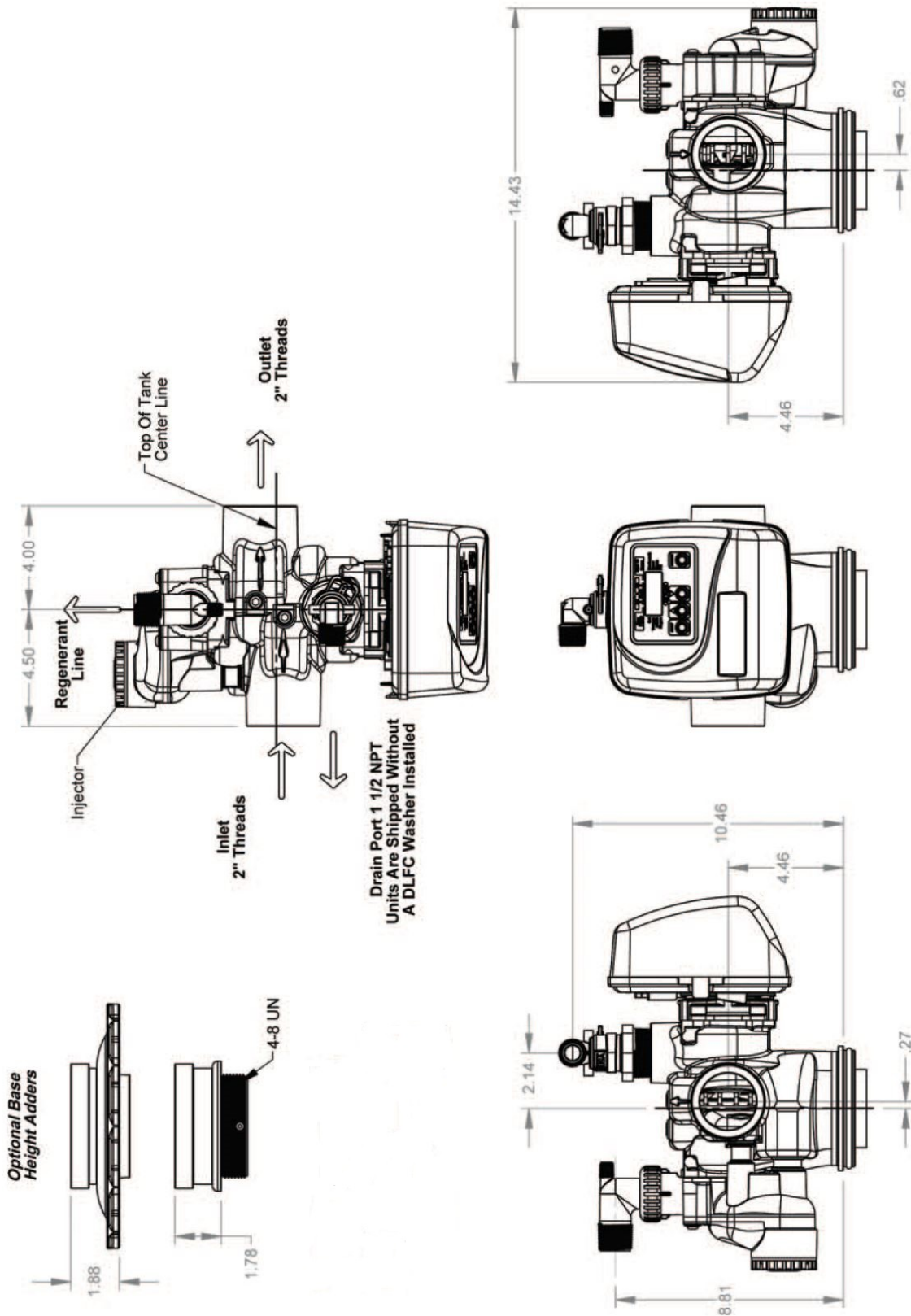

4.3) Flow Diagrams

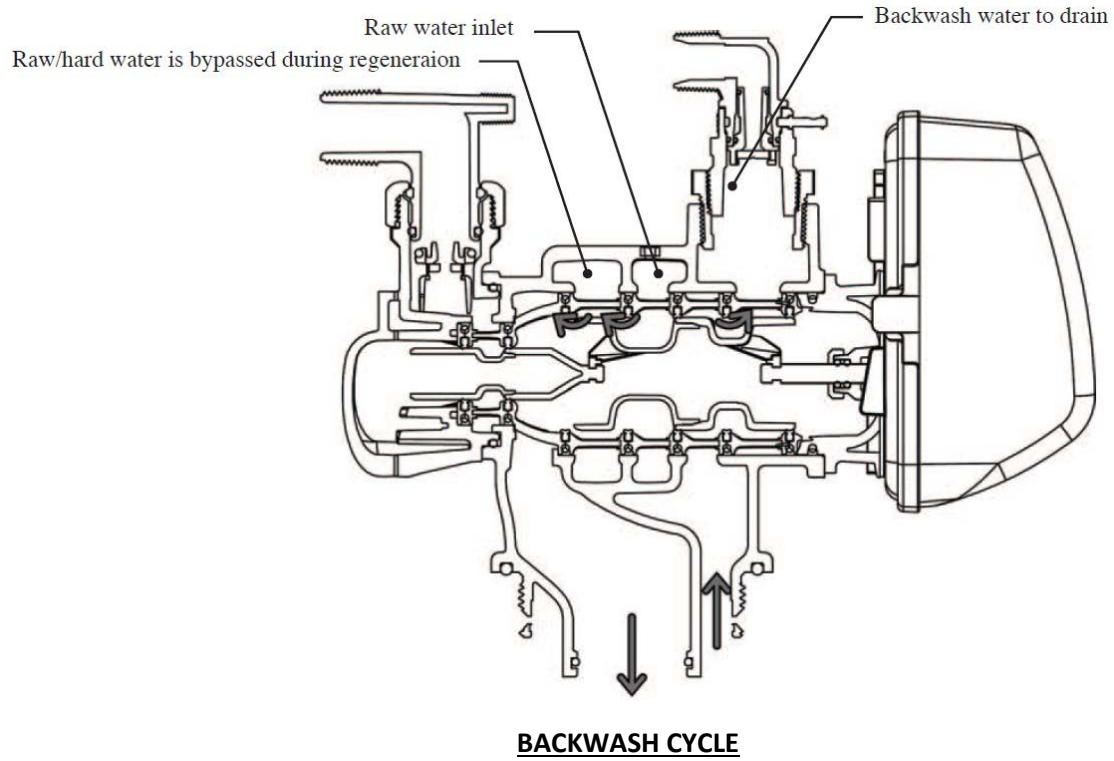
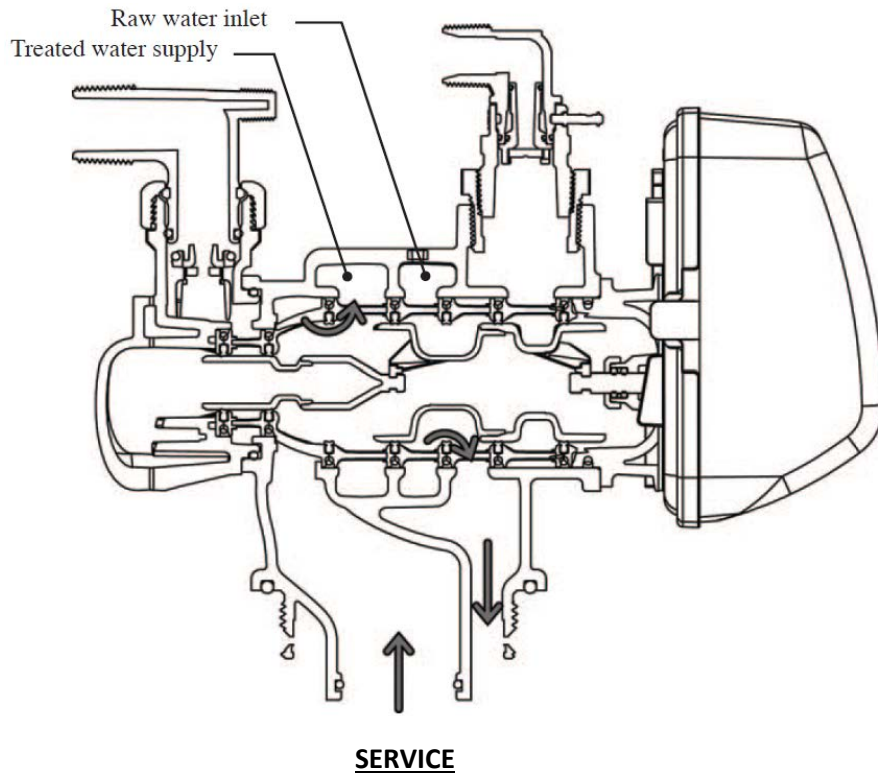

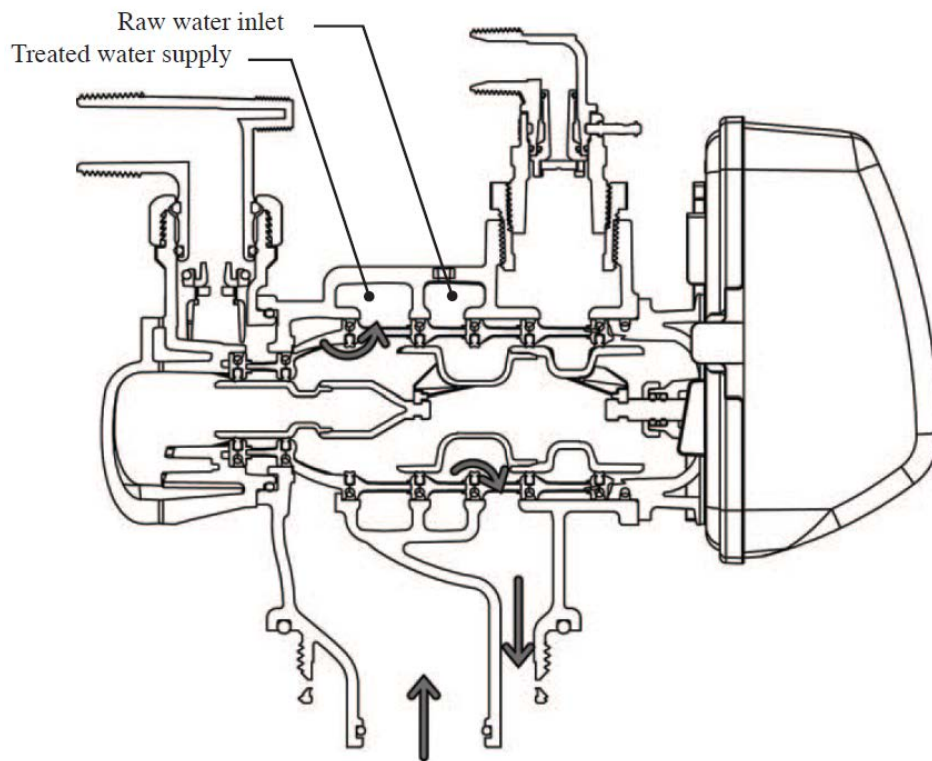
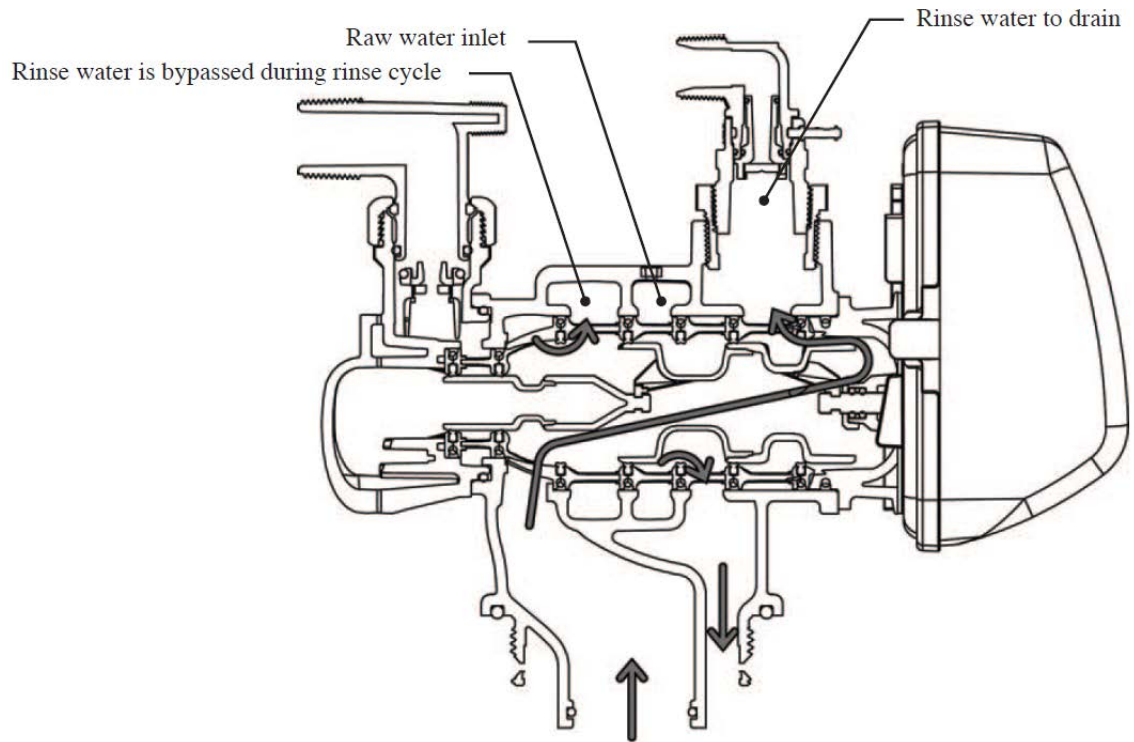

4.4) Components of Control Valve

4.4.1) Front Cover and PC Board

Drawing No.	Order No.	Description	Qty
1	CLK V3175EE01	WS1EE FRONT COVER ASSEMBLY	1
2	CLK V310701	WS1 MOTOR	1
3	CLK V310601	WS1 DRIVE BRACKET & SPRING CLIP	1
4	CLK V3408EE04BOARD	WS1THRU/2 EE PCB 5 DIGIT REPL	1
5	CLK V3110	WS1 DRIVE GEAR 12X36	3
6	CLK V3109	WS1 DRIVE GEAR COVER	1
Not Shown	CLK V3186	WS1 AC ADAPTER 120V-12V	1
	CLK V3186-01	WS1 AC ADAPTER CORD ONLY	
Not Shown	CLK V3178	WS1 Drive Back Plate	1

AC Adapter	U.S.
Supply Voltage	120 V AC
Supply Frequency	60 Hz
Output Voltage	12 V AC
Output Current	500 mA

Wiring for Correct On/Off Operation	
PC Board Relay Terminal Block	Relay
RLY 1	Coil -
+ COM	Coil +

When replacing the battery, align positives and push down to fully seat.

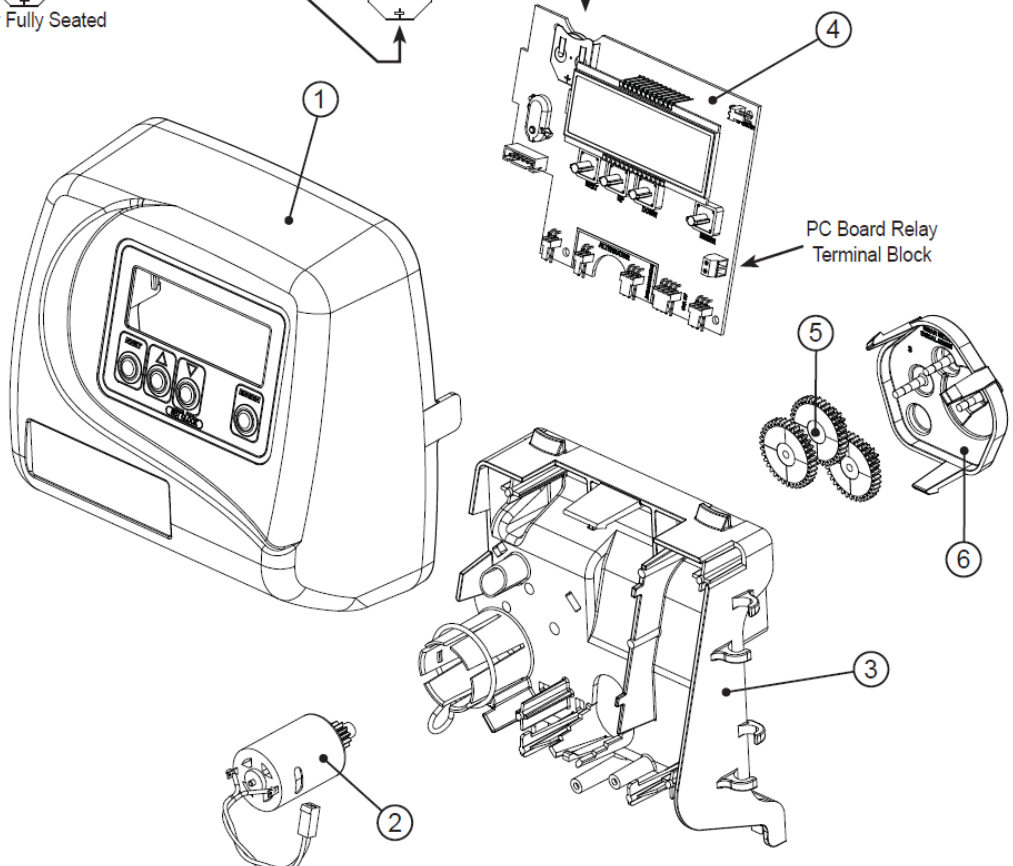
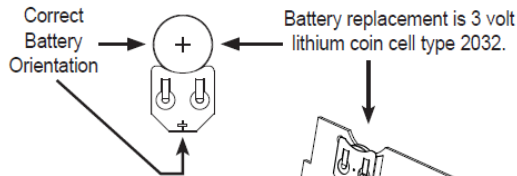
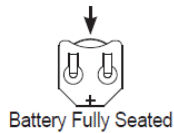

4.4.2) Drive assembly, Piston and Spacer stack

Drawing No.	Order No.	Description	Quantity
2	V3725	WS2 PISTON DOWNFLOW ASSEMBLY (AMBER IN COLOR)	1
3	V3452	O-RING 230	1
4	V3728	WS2 DRIVE CAP ASSEMBLY	1
5	V3724	WASHER FLAT SS 1/4	4
6	V3642	BOLT BHCS S/S 1/4-20X1.25	4
7	BACK PLATE	REFER TO PROGRAMMING AND COVER DRAWING MANUAL	1
8	V3729	WS2 STACK DOWNFLOW ASSEMBLY (BLACK IN COLOR)	1
9	V3279	O-RING 346	1
10	V3280	O-RING 332 FOR VALVE BODIES WITH NPT THREADS	1
11	V3737-01	WS2 BODY QC NPT	1
12	V3054*	WS2H 4IN BASE CLAMP ASSEMBLY	1
13	V3276	WS2H BOLT HEX 5/16 - 18 X 1-3/4	1
14	V3269	WS2H NUT 5/16 - 18 SS HEX	1
15	V3468	WS2H PLUG 1/4 HEX NPT	2
NOT SHOWN	D1300-01	TOP BAFFLE DFSR CLACK 2/63MM	1

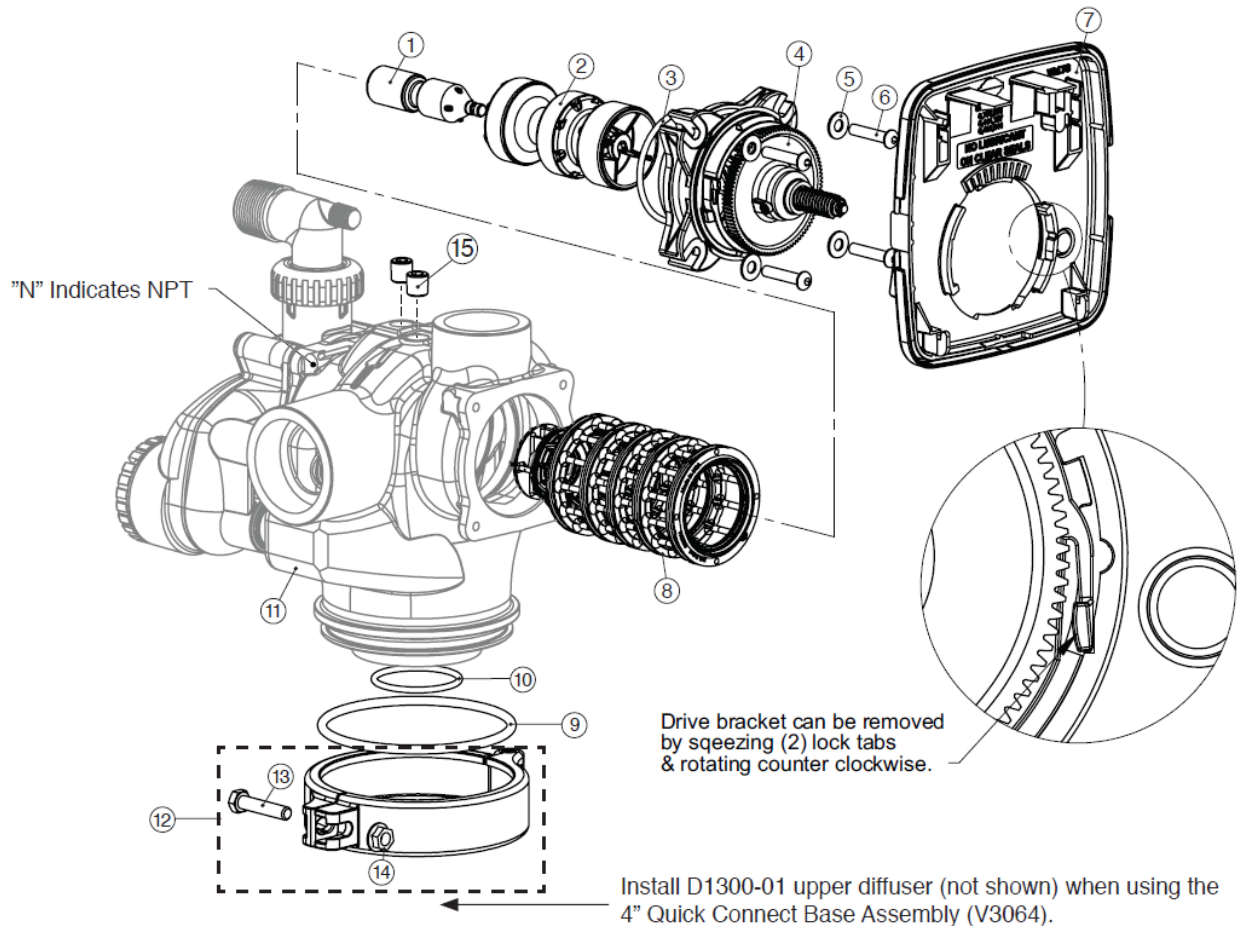

4.4.3) Base Adapters

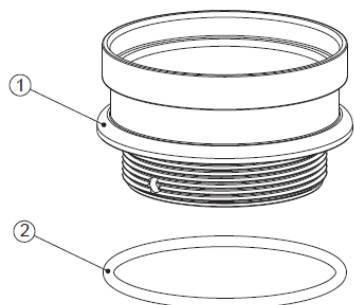

Drawing No.	Order No.	Description	Quantity
1	CLK V3202-01	WS2H BASE	1
2	CLK V3419	O-RING 347	1

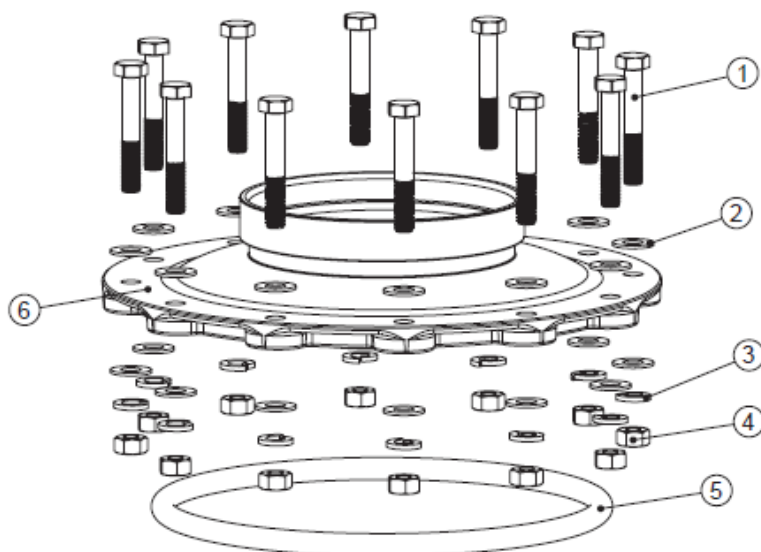

Drawing No.	Order No.	Description	Quantity
1	CLK V3444	WS2H SCREW HEXCAP 5/16-18X2 SS	12
2	CLK V3293	WS2H WASHER SS 5/16 FLAT	24
3	CLK V3445	WS2H WASHER SPLIT LOCK 5/16 SS	12
4	CLK V3447	WS2H NUT HEX 5/16-8 FULL SS	12
5	CLK COR60FL	O RING 6" FLANGE ADAPTER	1
6	CLK V326101	WS2H FLANGE BASE	1

4.4.4) Drain Line Flow Control

Item	Part#	Description	Qty.
CLK V315804		WS Drain Fitting, 3/4" Elbow	
1	CLK V315803	Drain Elbow, 3/4 NPT	1
2	CLK V315901	DLFC Retainer Assembly	1
3	CLK V3163	O-ring, -019	1
4	CLK H4615	Locking Clip	1
5	CLK V3983	WS2 DLFC Adapter	1
6	CLK V3162xx	See DLFC Section	1

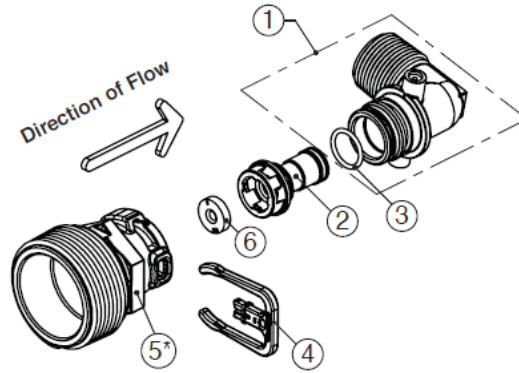

Item	Part#	Description	Qty.
CLK V300805		WS Drain Fitting, 1" Straight	
1	CLK V3167	WS Drain Fitting Adapter, 1"	1
2	CLK V316601	Drain Fitting Body	1
3	CLK V3151	WS1 Nut, QC	1
4	CLK V3150	WS1 Split Ring	1
5	CLK V3105	O-ring -215	1
6	CLK V3163	O-ring -019	1
7	CLK H4615	Locking Clip	1
8	CLK V3983	WS2 DLFC Adapter	1
9	CLK V3190xx	See DLFC Section	1

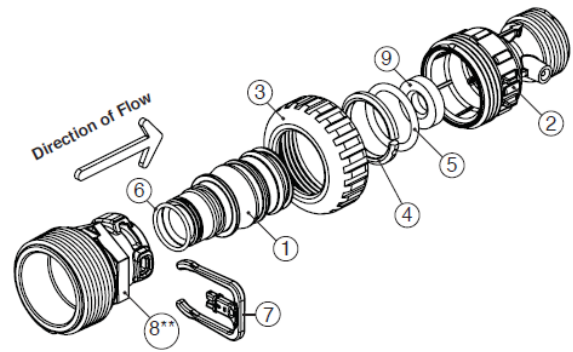

Item	Order No.	Description	Qty.
CLK V3080		WS Drain Fitting, 1.5" Straight	
1	CLK V3081	WS15 RETAINER DLFC ASY	1
2	CLK V3645	WS15 DLFC FLANGE OUTLET FNPT	1
3	CLK V3646	WS15 DLFC FLANGE INLET MNPT	1
4	CLK V3652	BOLT HEXHD S/S HCS 5/16-18x3/4	4
5	CLK V3441	O-RING 226	1
6	CLK V3162xx	See DLFC Section	0-6
7	CLK V3190xx	See DLFC Section	1

V3162-XXX

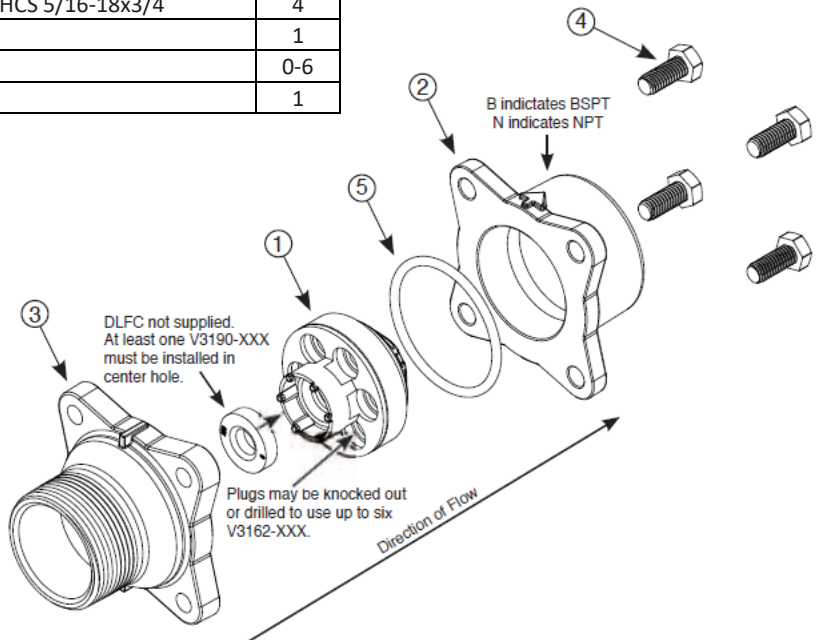
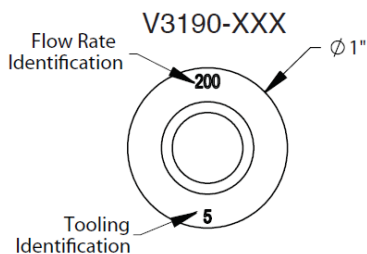
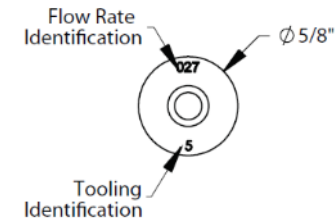

4.4.5) Outlet Meter Assembly

Note: Be sure the proper meter size is programmed in the software.

Standard meter cable used for spacing up to 3" between valve body and meter body, longer distance requires longer cable #V3221.

Service or replace the turbine by:

1. Turn the bypass for the system on and relieve the pressure on the system before removing the meter.
2. Press downward on the remote meter assembly to relieve tension on the retaining clip V3632.

Remove the clip and take the meter assembly out of the housing.

3. Remove the bend from the two exposed tips of the retaining clip V3501 and remove clip.
4. Service or replace the V3118-03 WS15/2 Turbine Assembly and place it back on the turbine shaft.
5. Insert the V3501 WS15/2 Turbine Clip and re-bend the exposed ends of the clip. The V3118-03 turbine has a groove to line up with the V3501 WS15/2 Turbine Clip.
6. Insert meter assembly back into the meter housing.
7. Re-install the meter retaining clip V3632 as shown below.

8. Open the bypass for the system slowly to bring back into service and check to be sure you have no water leaks.

The V3118-03 has a groove to line up with the V3501 WS1.5/2 Turbine Clip.

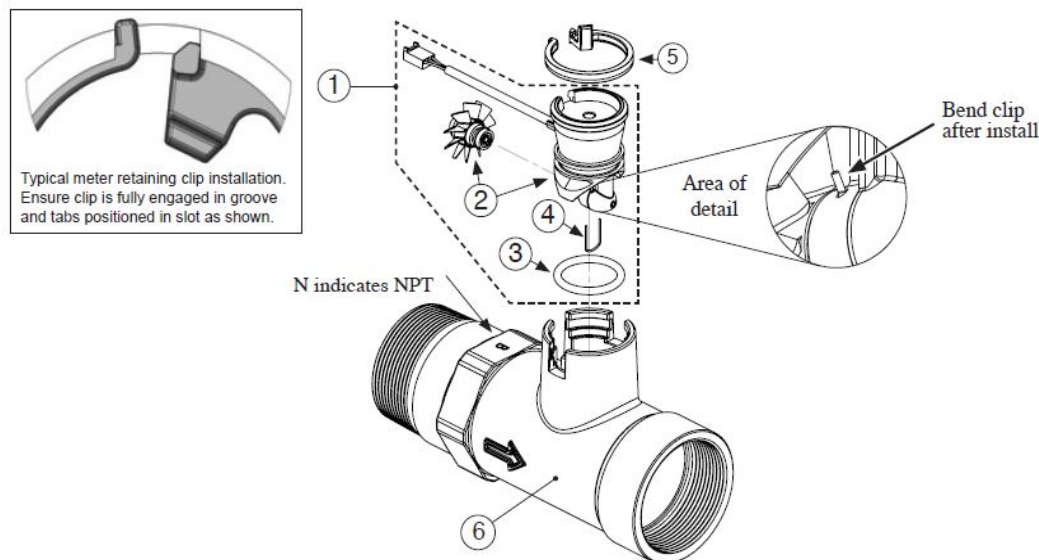

V3094	2" NPT Meter, 28" Cable
V3094-15	2" NPT Meter, 15' Cable

Drawing No.	Order No.	Description	Quantity
1	CLK V3003-02	Commercial meter assembly, 28" Cable	1
	CLK V3221	Commercial meter assembly, 15' Cable	
2	CLK V3118-03	Commercial meter turbine assembly	1
3	CLK V3105	O-ring, -215	1
4	CLK V3501	Turbine clip	1
5	CLK V3632	Meter Retaining Clip	1
6	CLK V3754-01	WS2 Meter Housing NPT	1
Not Shown	CLK V3488	WS2 Flow Straightener	1

5) QUICK REFERENCE GUIDE

Manual Regeneration

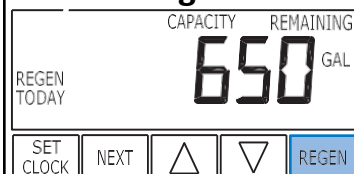

Immediate Regeneration: - Press and hold "REGEN" button for more than 3 seconds. Press "REGEN" button to advance the unit to next cycle in regeneration.

Delayed Regeneration: - Press and release "REGEN" button once the "REGEN TODAY" will be flashing on screen. Now the regeneration will occur tonight at preset time. The delayed regeneration can be cancelled by pressing "REGEN" button again.

Note: - If brine tank needs to be refilled please fill the salt at least two hours before regeneration.

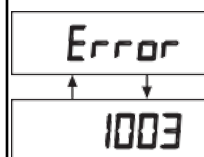

This error screen and error number will toggle. Contact Service Technician or OEM and report the error code.

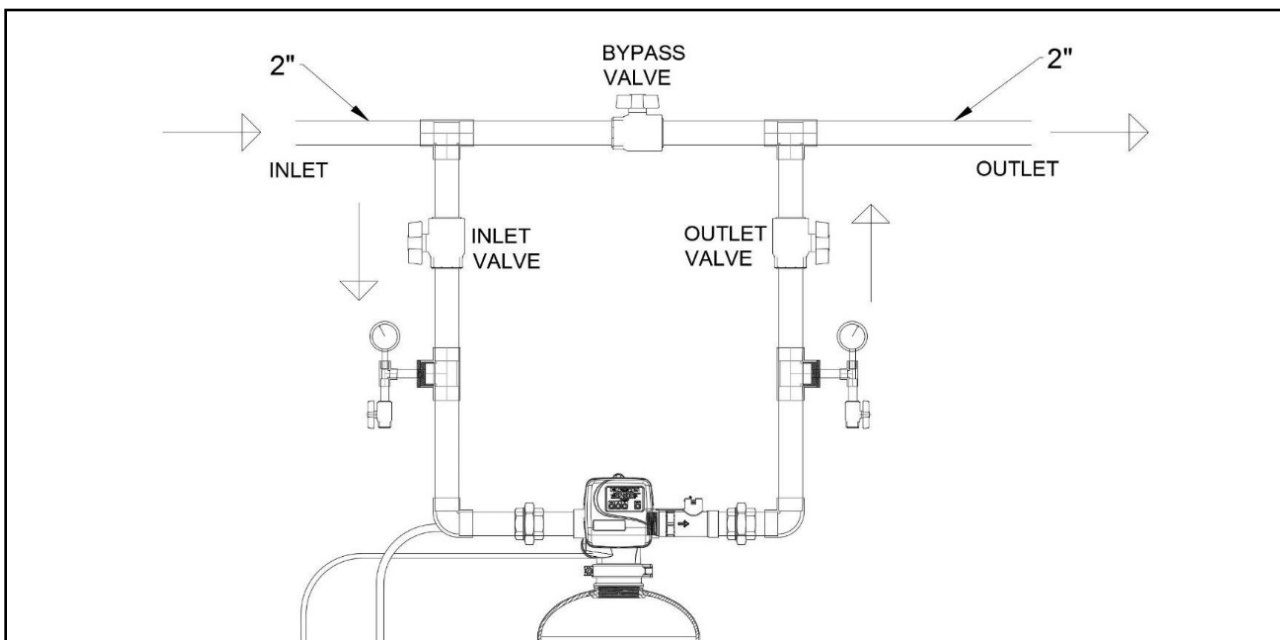

Normal Position: - The inlet and outlet valve must be fully open and bypass valve must be fully closed.

Bypass Position: - To shut off supply to the Unit the inlet and outlet valves must be fully closed and bypass valve must be fully open.

6) SERVICE INSTRUCTIONS

6.1) Front Cover Removal

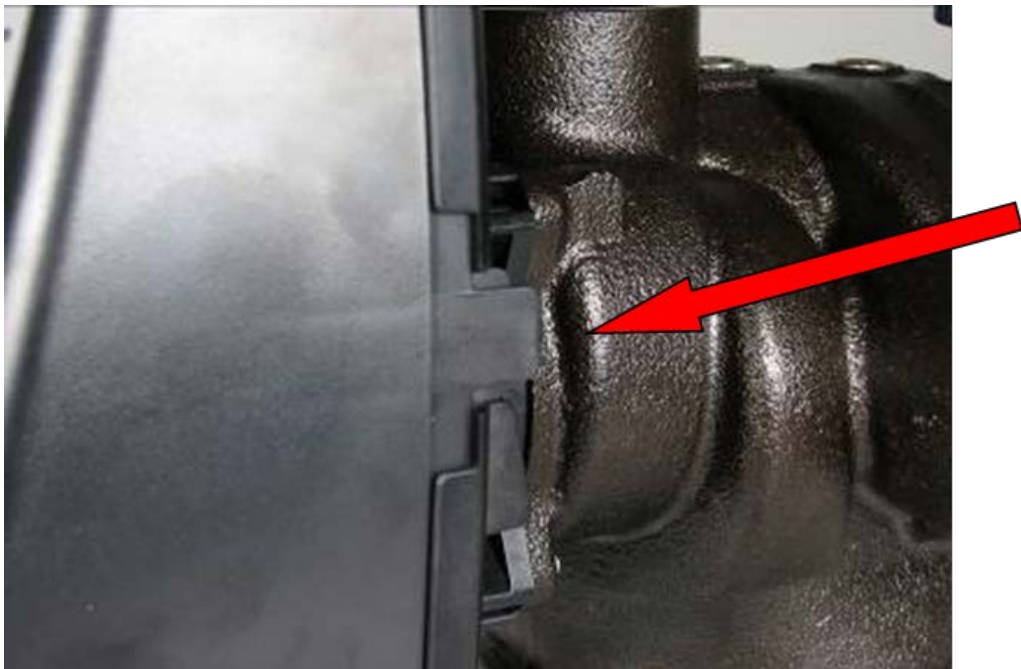

Pull out on each side of the covers locking tabs

6.2) PC Board Removal

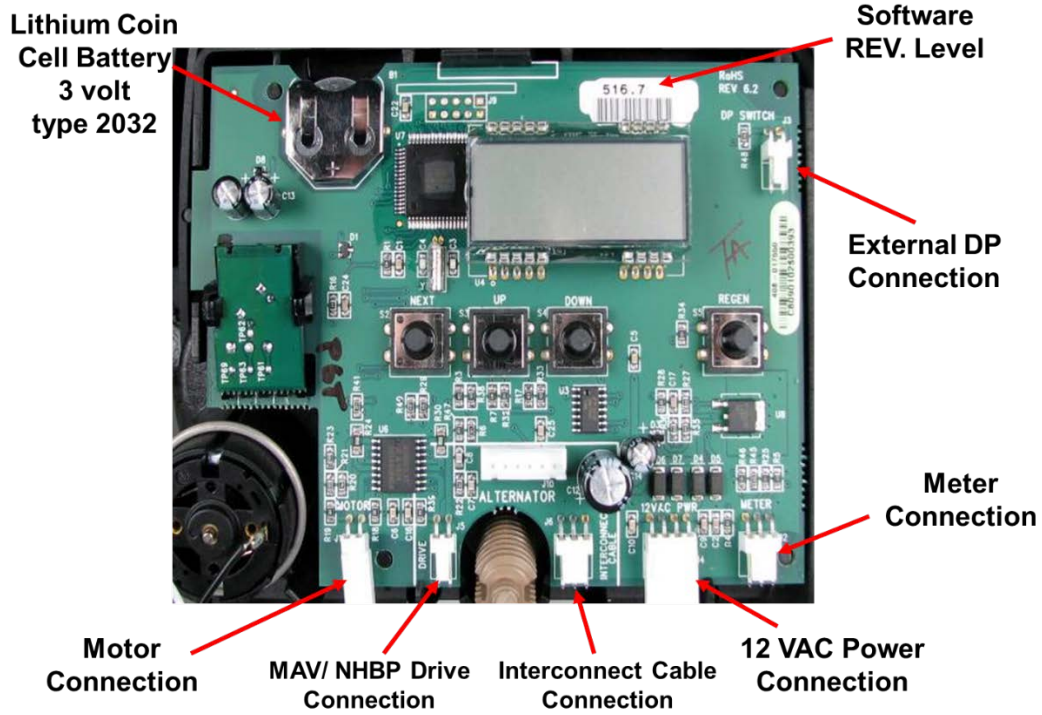

Disconnect the power cable first and then disconnect other cables.

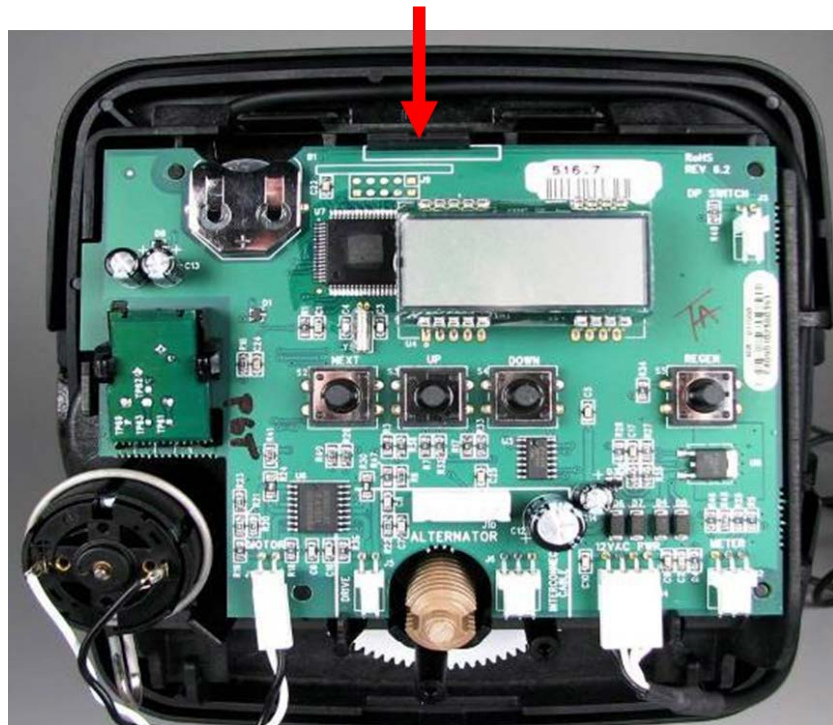

Lift up the locking tab and then pull out the PC board from top.

6.3) Drive Bracket Removal



Lift up both locking tabs and pull out the bracket.



Motor can be removed by pressing the locking spring to the right and then pull the motor out. Gearbox can be removed by pushing the beige colored locking tabs inwards.

6.4) Backplate Removal

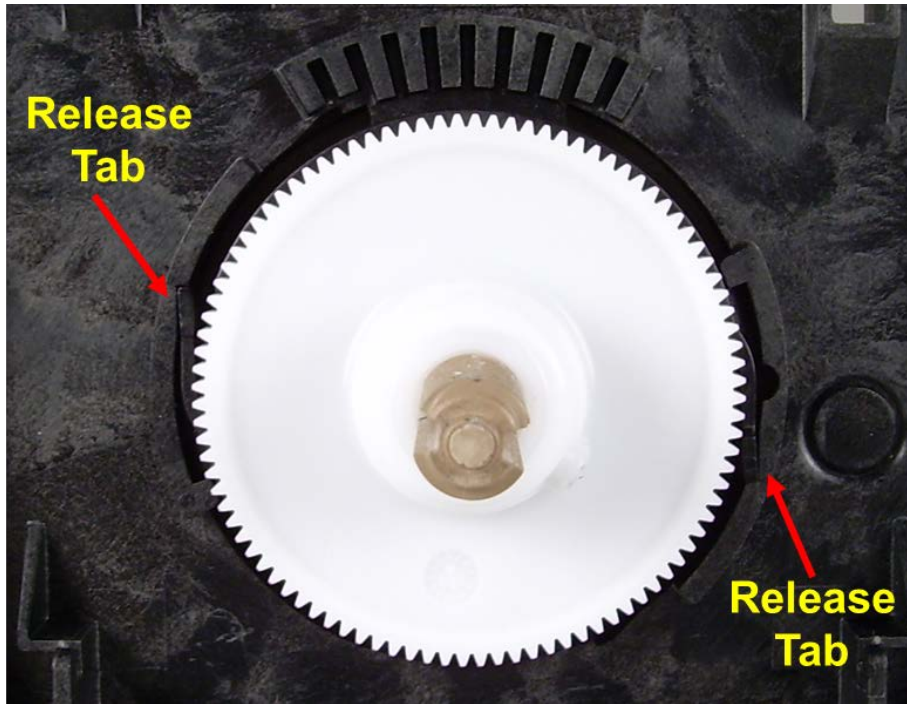

Squeeze two release tabs to inside direction



After squeezing release tabs, turn the backplate counter clockwise

6.5) Drive Cap Removal



Use 5/32 Allen wrench to Remove Drive Cap Bolts



After taking bolts off, pull out the drive cap with main piston & brine piston

6.6) Stack Assembly



Pull out the spacer stack assembly

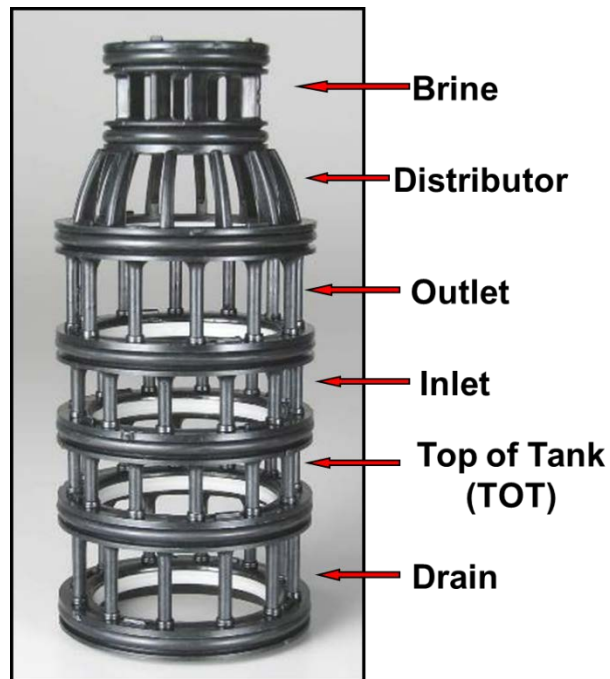

7) TROUBLESHOOTING

7.1) Possible Error Codes

Possible Errors	
Code	Description
Err-1001	Control unable to sense motor movement
Err-101	
Err-1002	Control Valve motor ran too short
Err-102	
Err-1003	Control Valve motor ran too long and unable to find next cycle
Err-103	
Err-1004	Control Valve ran too long and timed out
Err-104	
Err-1006	MAV/NHWB motor ran too long
Err-106	
Err-1007	MAV/NHWB motor ran too short and stalled
Err-107	

7.2) Troubleshooting Procedures

Problem	Possible Cause	Solution
1. No Display on PC Board	a. No power at electric outlet	a. Repair outlet or use working outlet
	b. Control valve Power Adapter not plugged into outlet or power cord end not connected to PC board connection	b. Plug Power Adapter into outlet or connect power cord end to PC Board connection
	c. Improper power supply	c. Verify proper voltage is being delivered to PC Board
	d. Defective Power Adapter	d. Replace Power Adapter
	e. Defective PC Board	e. Replace PC Board
2. PC Board does not display correct time of day	a. Power Adapter plugged into electric outlet controlled by light switch	a. Use uninterrupted outlet
	b. Tripped breaker switch and/or tripped	b. Reset breaker switch and/ or GFI switch
	c. Power outage	c. Reset time of day. If PC Board has battery back up present the battery may be depleted. See Front Cover and Drive Assembly drawing for instructions.
	d. Defective PC Board	d. Replace PC Board
3. Display does not indicate that water is flowing. Refer to user instructions for how the display indicates water is flowing	a. Bypass valve in bypass position	a. Turn bypass handles to place bypass in service position
	b. Meter is not connected to meter connection on PC Board	b. Connect meter to three pin connection labeled METER on PC Board
	c. Restricted/ stalled meter turbine	c. Remove meter and check for rotation or foreign material
	d. Meter wire not installed securely into three pin connector	d. Verify meter cable wires are installed securely into three pin connector labeled METER
	e. Defective meter	e. Replace meter
	f. Defective PC Board	f. Replace PC Board
4. Control valve regenerates at wrong time of day	a. Power outage	a. Reset time of day. If PC Board has battery back up present the battery may be depleted. See Front Cover and Drive Assembly drawing for instructions.
	b. Time of day not set correctly	b. Reset to correct time of day
	c. Time of regeneration set incorrectly	c. Reset regeneration time
	d. Control valve set at "on 0" (immediate regeneration)	d. Check programming setting and reset to NORMAL (for a delayed regen time)
	e. Control valve set at "NORMAL + on 0" (delayed and/ or immediate)	e. Check programming setting and reset to NORMAL (for a delayed regen time)
5. Time of day flashes on and off	a. Power outage	a. Reset time of day. If PC Board has battery back up present the battery may be depleted. See Front Cover and Drive Assembly drawing for instructions.
6. Control valve does not regenerate automatically when the REGEN button is depressed and held.	a. Broken drive gear or drive cap assembly	a. Replace drive gear or drive cap assembly
	b. Broken Piston Rod	b. Replace piston rod
	c. Defective PC Board	c. Defective PC Board
7. Control valve does not regenerate automatically but does when the REGEN button is depressed and held.	a. Bypass valve in bypass position	a. Turn bypass handles to place bypass in service position
	b. Meter is not connected to meter connection on PC Board	b. Connect meter to three pin connection labeled METER on PC Board
	c. Restricted/ stalled meter turbine	c. Remove meter and check for rotation or foreign material
	d. Incorrect programming	d. Check for programming error
	e. Meter wire not installed securely into three pin connector	e. Verify meter cable wires are installed securely into three pin connector labeled METER
	f. Defective meter	f. Replace meter
	g. Defective PC Board	g. Replace PC Board

FILTER INSTALLATION AND USER GUIDE

Problem	Possible Cause	Solution
8. Unfiltered water is being delivered	a. Bypass valve is open or faulty	a. Fully close bypass valve or replace
	b. Media is exhausted due to high water usage	b. Check program settings or diagnostics for abnormal water usage
	c. Meter not registering	c. Remove meter and check for rotation or foreign material
	d. Water quality fluctuation	d. Test water and adjust program values accordingly
	e. No regenerant or low level of regenerant in regenerant tank	e. Add proper regenerant to tank
	f. Control fails to draw in regenerant	f. Refer to Trouble Shooting Guide number 12
	g. Insufficient regenerant level in regenerant tank	g. Check refill setting in programming. Check refill flow control for restrictions or debris and clean or replace
	h. Damaged seal/stack assembly	h. Replace seal/stack assembly
	i. Control valve body type and piston type mix matched	i. Verify proper control valve body type and piston type match
	j. Fouled media bed	j. Replace media bed
9. Water running to drain	a. Power outage during regeneration	a. Upon power being restored control will finish the remaining regeneration time. Reset time of day.
	b. Damaged seal/ stack assembly	b. Replace seal/ stack assembly
	c. Piston assembly failure	c. Replace piston assembly
	d. Drive cap assembly not tightened in properly	d. Re-tighten the drive cap assembly
10. E1, Err – 1001, Err – 101 = Control unable to sense motor movement	a. Motor not inserted full to engage pinion, motor wires broken or disconnected	a. Disconnect power, make sure motor is fully engaged, check for broken wires, make sure two pin connector on motor is connected to the two pin connection on the PC Board labeled MOTOR. Press NEXT and REGEN buttons for 3 seconds to resynchronize software with piston position or disconnect power supply from PC Board for 5 seconds and then reconnect.
	b. PC Board not properly snapped into drive bracket	b. Properly snap PC Board into drive bracket and then Press NEXT and REGEN buttons for 3 seconds to resynchronize software with piston position or disconnect power supply from PC Board for 5 seconds and then reconnect.
	c. Missing reduction gears	c. Replace missing gears

FILTER INSTALLATION AND USER GUIDE

Problem	Possible Cause	Solution
11. E2, Err – 1002, Err – 102 = Control valve motor ran too short and was unable to find the next cycle position and stalled	a. Foreign material is lodged in control valve	a. Open up control valve and pull out piston assembly and seal/ stack assembly for inspection. Press NEXT and REGEN buttons for 3 seconds to resynchronize software with piston position or disconnect power supply from PC Board for 5 seconds and then reconnect.
	b. Mechanical binding	b. Check piston and seal/ stack assembly, check reduction gears, check drive bracket and main drive gear interface. Press NEXT and REGEN buttons for 3 seconds to resynchronize software with piston position or disconnect power supply from PC Board for 5 seconds and then reconnect.
	c. Main drive gear too tight	c. Loosen main drive gear. Press NEXT and REGEN buttons for 3 seconds to resynchronize software with piston position or disconnect power supply from PC Board for 5 seconds and then reconnect.
	d. Improper voltage being delivered to PC Board	d. Verify that proper voltage is being supplied. Press NEXT and REGEN buttons for 3 seconds to resynchronize software with piston position or disconnect power supply from PC Board for 5 seconds and then reconnect.
12. E3, Err – 1003, Err – 103 = Control valve motor ran too long and was unable to find the next cycle position	a. Motor failure during a regeneration	a. Check motor connections then Press NEXT and REGEN buttons for 3 seconds to resynchronize software with piston position or disconnect power supply from PC Board for 5 seconds and then reconnect.
	b. Foreign matter built up on piston and stack assemblies creating friction and drag enough to time out motor	b. Replace piston and stack assemblies. Press NEXT and REGEN buttons for 3 seconds to resynchronize software with piston position or disconnect power supply from PC Board for 5 seconds and then reconnect.
	c. Drive bracket not snapped in properly and out enough that reduction gears and drive gear do not interface	c. Snap drive bracket in properly then Press NEXT and REGEN buttons for 3 seconds to resynchronize software with piston position or disconnect power supply from PC Board for 5 seconds and then reconnect.
13. Err – 1004, Err – 104 = Control valve motor ran too long and timed out trying to reach home position	a. Drive bracket not snapped in properly and out enough that reduction gears and drive gear do not interface	a. Snap drive bracket in properly then Press NEXT and REGEN buttons for 3 seconds to resynchronize software with piston position or disconnect power supply from PC Board for 5 seconds and then reconnect.

8) 5 YEAR WARRANTY

Commercial Duplex Water Filter

Thank you for your purchase of our COMMERCIAL DUPLEX WATER FILTER. For proof of purchase, please retain your Invoice/Sales Order Copy.

Warranty ~ Offered

Excalibur Water Systems warrants its products to be free from defect in materials and workmanship to the original owner from the date on the proof of purchase as described below.

Warranty ~ Working Procedures

If during the suitable warranty period, a part is defective, then Excalibur Water Systems will repair or replace that part at no charge to the original owner, with the exception of charges for nominal shipping, service and/or installation.

Warranty ~ Coverage Outlined

Excalibur Water Systems guarantees, to the original owner, a period of 5 years, the CONTROL BODY to be free of defects in materials and workmanship and to perform its proper functions. To the original owner, a period of 5 years, the ELECTRONIC CONTROL VALVES as well as all parts to be free of defects in materials and workmanship and to perform their normal functions. To the original owner, the SALT TANK and the MINERAL TANKS will not rust, corrode, leak, burst or in any other form fail to perform their proper functions for a period of 10 YEARS.

Warranty ~ Service

In the event you require service, Excalibur Water Systems Dealer will provide all necessary service and installation for your Commercial Water Filter. To obtain warranty service within 30 days of discovery of the defect, notification must be given to Excalibur Water Systems.

General Provisions

The above warranties are effective provided the WATER FILTER is operated at water pressures not exceeding 125psi and at water temperatures not exceeding 120°F; also provided that the water filter is not subject to abuse, misuse, alteration, neglect, freezing, accident or negligence; and provided further that the water filter is not damaged as the result of any unusual force of nature such as, but not limited to flood, hurricane, tornado or earthquake. Excalibur Water Systems is excused if failure to perform its warranty obligations is the result of strikes, government regulation, materials shortages or other circumstances beyond its control.

THERE ARE NO WARRANTIES ON THE WATER FILTER BEYOND THOSE SPECIFICALLY DESCRIBED ABOVE. ALL IMPLIED WARRANTIES, INCLUDING ANY IMPLIED WARRANTY OF MERCHANTABILITY OR OF FITNESS FOR A PARTICULAR PURPOSE, ARE DISCLAIMED TO THE EXTENT THEY MIGHT EXTEND BEYOND THE ABOVE PERIODS. THE SOLE OBLIGATION OF EXCALIBUR WATER SYSTEMS UNDER THESE WARRANTIES IS TO REPLACE OR REPAIR THE COMPONENT OR PART PROVES TO BE DEFECTIVE WITHIN THE SPECIFIED TIME PERIOD AND EXCALIBUR WATER SYSTEMS IS NOT LIABLE FOR CONSEQUENTIAL OR INCIDENTAL DAMAGES. NO DEALER, AGENT, REPRESENTATIVE OR OTHER PERSON IS AUTHORIZED TO EXTEND OR EXPAND THE WARRANTIES EXPRESSED ABOVE.

Certain provinces or states do not allow limitations on how long an implied warranty lasts or exclusions or limitations of incidental or consequential damage, therefore limitations and exclusions in this warranty may not apply to you. This warranty extends you specific legal rights as you may have other rights which vary from province to province or state to state.

Excalibur Water Systems is a manufacturer of water treatment products.

142 Commerce Park Drive

Barrie, Ontario Canada

