

CONTROL VALVE (in)	PIPING CONNECTIONS (in)				MINERAL TANK (in)	BRINE TANK (in)	RESIN PER VESSEL (ft³)	CAPACITY(GRAINS)				FLOW RATE (gpm)					WEIGHT (lbs)		
	INLET	OUTLET	DRAIN	BRINE				15 lbs/ft³	10 lbs/ft³	6 lbs/ft³	MAX SYSTEM	MIN	CRITICAL	SERVICE	15psi ΔP	25psi ΔP	BACKWASH	SHIPPING	OPERATING
1.0	1.0	1.0	0.75	0.375	13 X 54	18 X 40	2.5	75,000	67,500	50,000	75,000	1.8	7.5	11.0	19.0	25.0	4.2	225	905

REVISION HISTORY				
REV	DESCRIPTION	DATE	DESIGNER	APPROVED
A	INITIAL RELEASE	2022-02-02	CSIDDARUSHI	M. GARNER

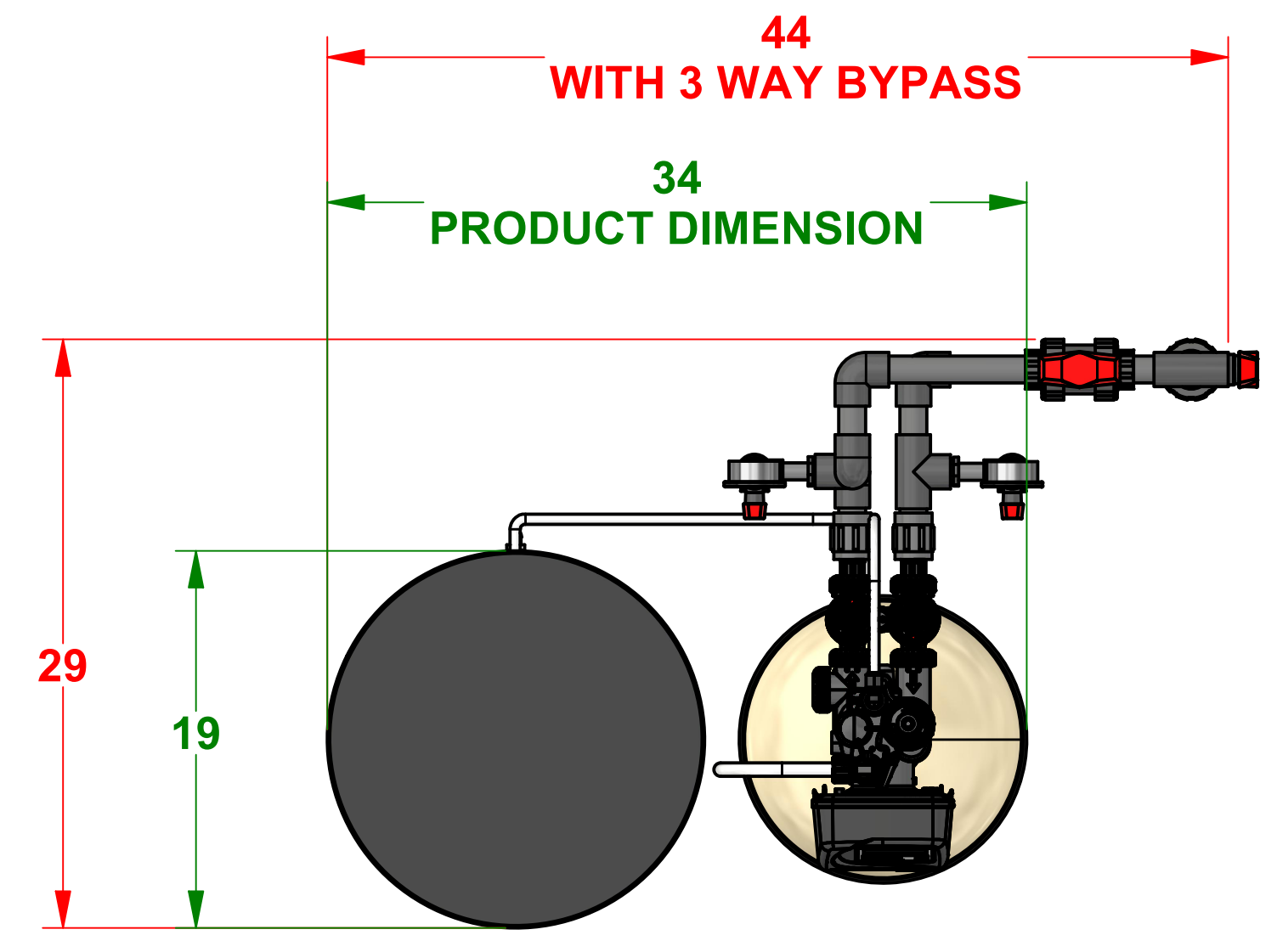

TOP VIEW

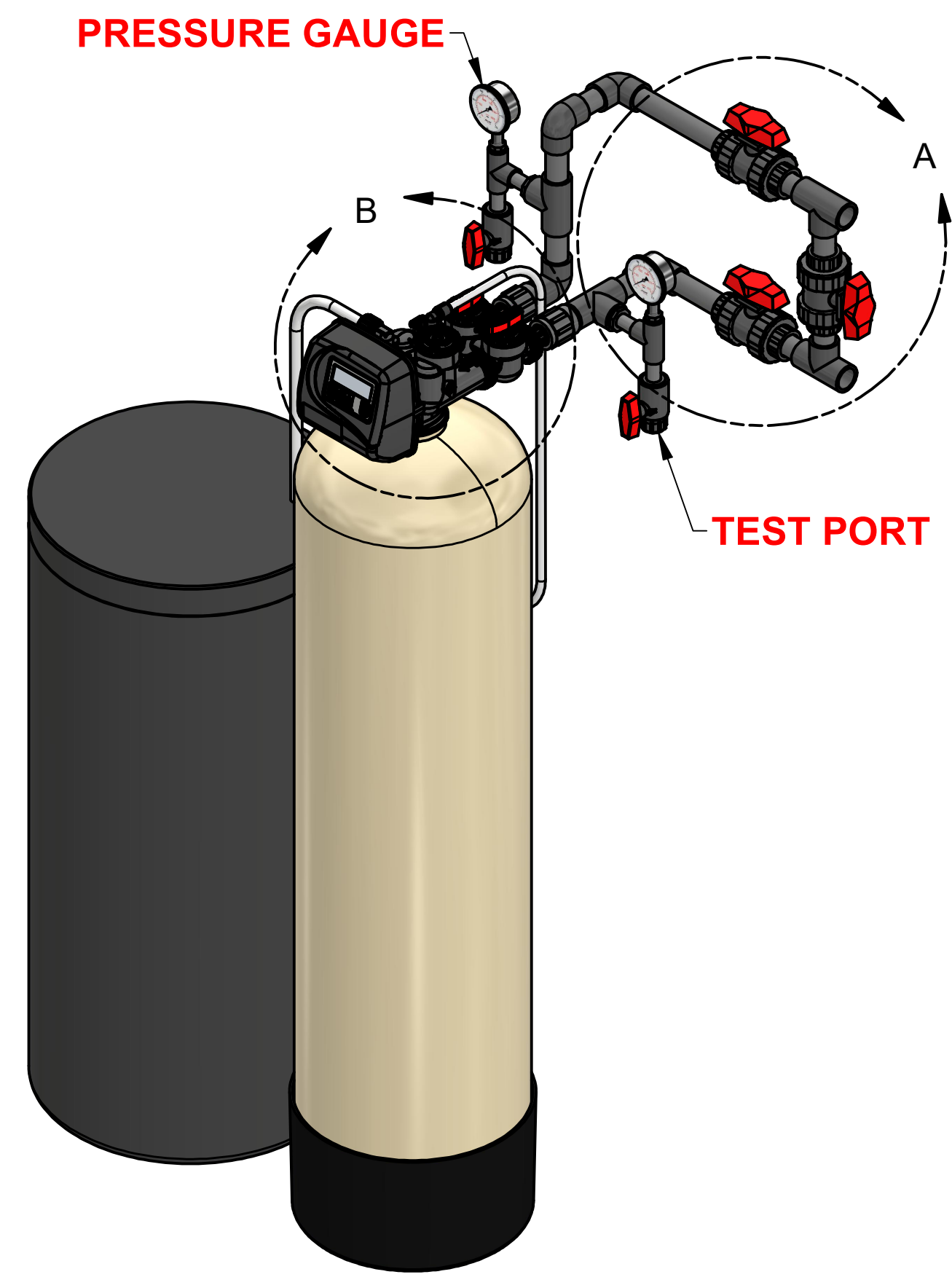

ISOMETRIC VIEW

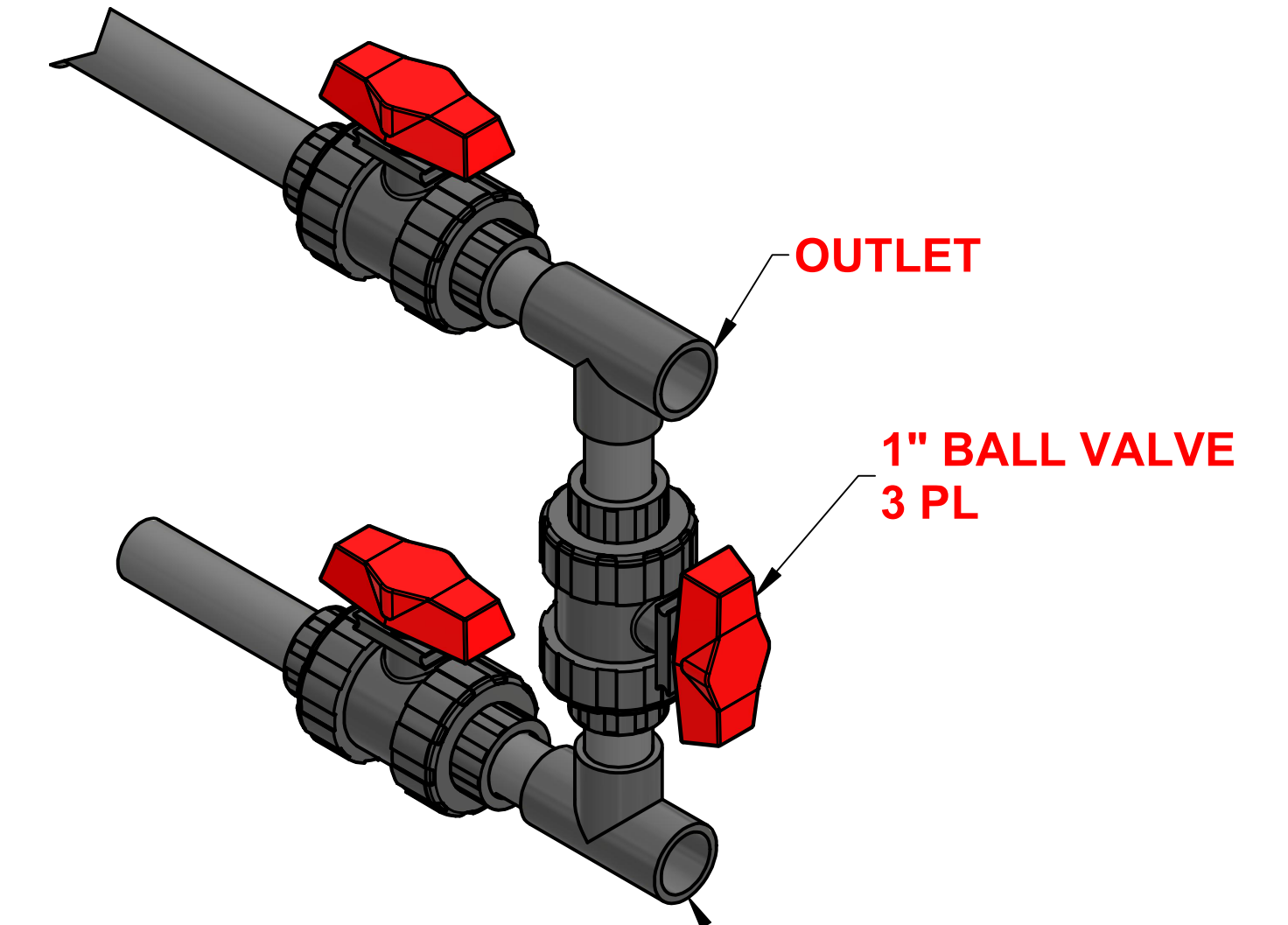

DETAIL A
SCALE 0.31 : 1
OPTIONAL 3 WAY BYPASS

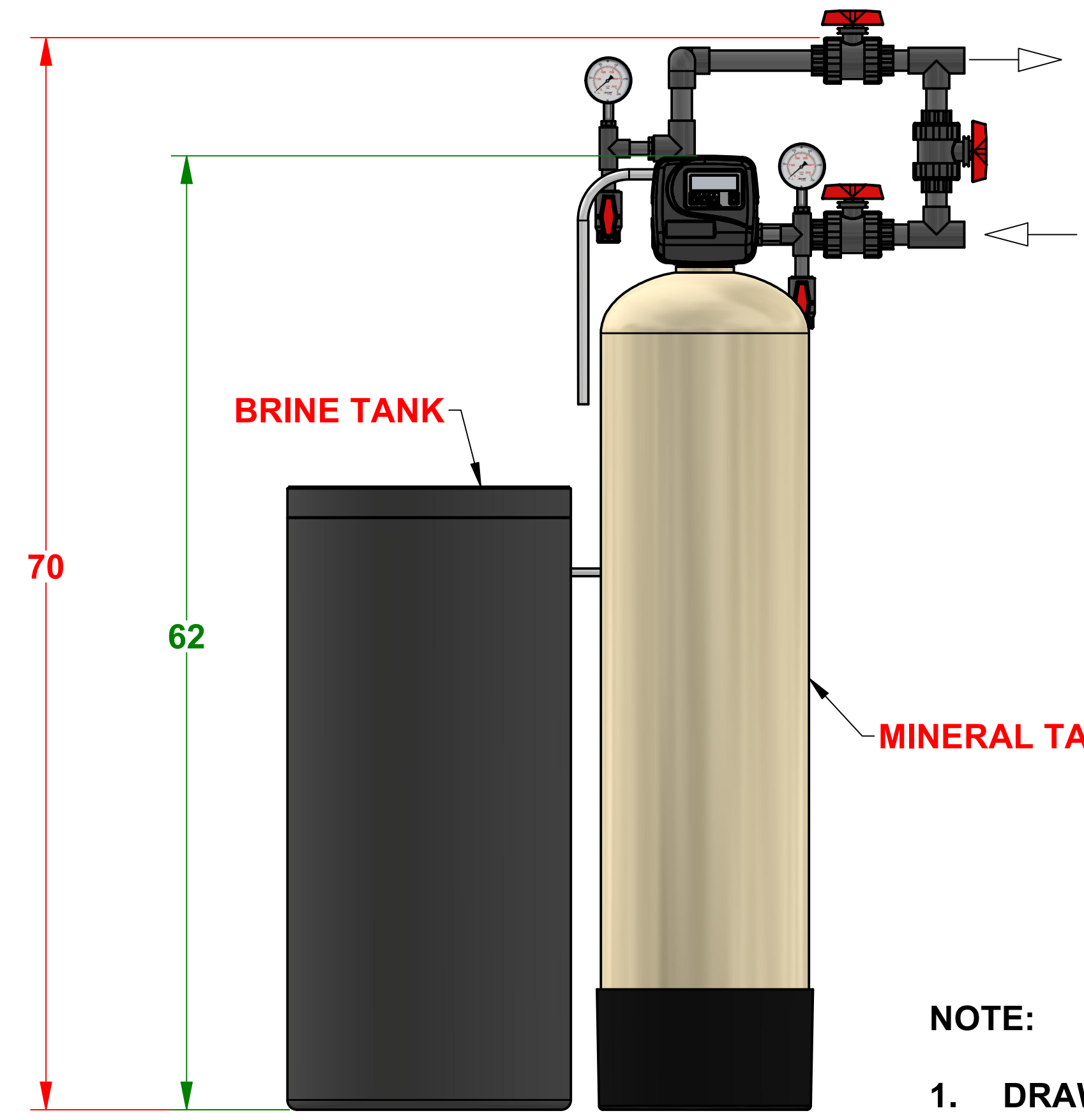

FRONT VIEW

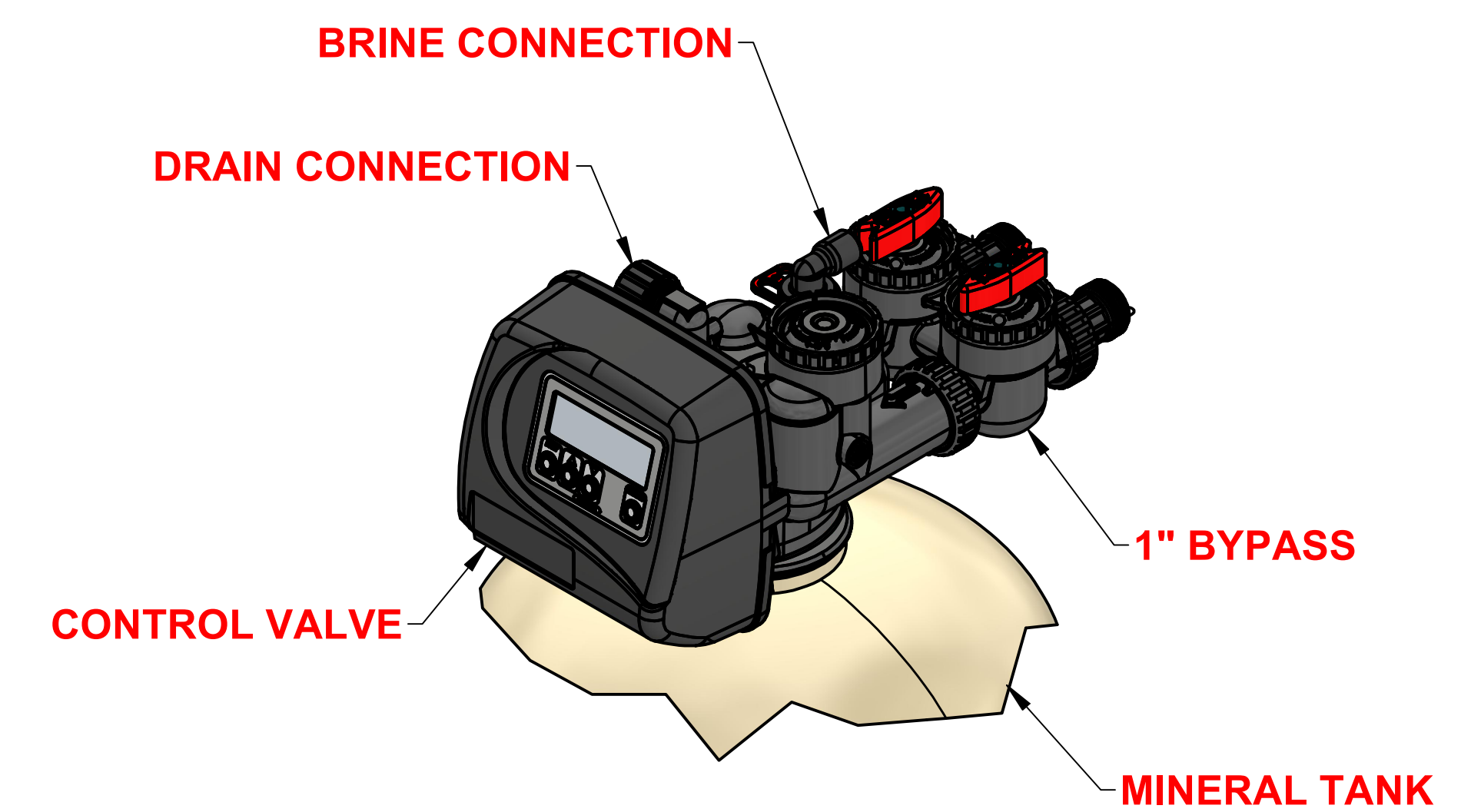

DETAIL B
SCALE 0.31 : 1

NOTE:

1. DRAWING IS FOR REFERENCE ONLY.
2. PIPING AND INSTRUMENTATION SHOWN ARE NOT INCLUDED IN THE SCOPE.
3. RECOMMEND INSTALLING HORIZONTAL FLEX CONNECTORS ON BOTH INLET AND OUTLET FOR FRP TANK EXPANSION.
4. RECOMMEND INSTALLING VACUUM BREAKER(S) ON ALL INLET FRP TANK CONNECTIONS.
5. PROVIDE AN AIR GAP ON DRAIN LINE OF AT LEAST 4 TIMES THE DIAMETER OF THE PIPE OR FOLLOW LOCAL PLUMBING CODES.



UNLESS OTHERWISE SPECIFIED dimensions are in inches. Tolerance on: Decimals .XXX = ± .5 .XX = ± 1 .X = ± 2	DRAWN CSIDDARUSHI	2022-02-02	TITLE WATER SOFTENER 1.0" SIMPLEX 75,000 CAPACITY
	CHECKED M. GARNER	2022-02-02	
	PROJECT MGR M. GARNER	2022-02-02	DRW NO: EWS S175
	ELE ENGINEER NA	2022-02-02	SCALE 1/8
	APPROVED M. GARNER	2022-02-02	SHEET 1 OF 1

This drawing contains information and data which is proprietary to Excalibur Water Systems Inc. This drawing, or any portion thereof, may not be reproduced, copied, or duplicated in any manner, nor used for manufacturing, without the written permission of Excalibur Water Systems Inc.