

CONTROL VALVE (in)	PIPING CONNECTIONS (in)				MINERAL TANK (in)	BRINE TANK (in)	RESIN PER VESSEL (ft³)	CAPACITY (GRAINS)				FLOW RATE (gpm)					WEIGHT (lbs)		
	INLET	OUTLET	DRAIN	BRINE				15 lbs/ft³	10 lbs/ft³	6 lbs/ft³	MAX SYSTEM	MIN	CRITICAL	SERVICE	15psi ΔP	25psi ΔP	BACKWASH	SHIPPING	OPERATING
2.0	2.0	2.0	2.0	0.75	42 X 72	50 X 60	25.0	750,000	675,000	500,000	2,250,000	19.2	225.0	345.0	318.0	375.0	45.0	7,670	28,500

REVISION HISTORY				
REV	DESCRIPTION	DATE	DESIGNER	APPROVED
A	INITIAL RELEASE	2022-11-22	CSiddarushi	M. GARNER

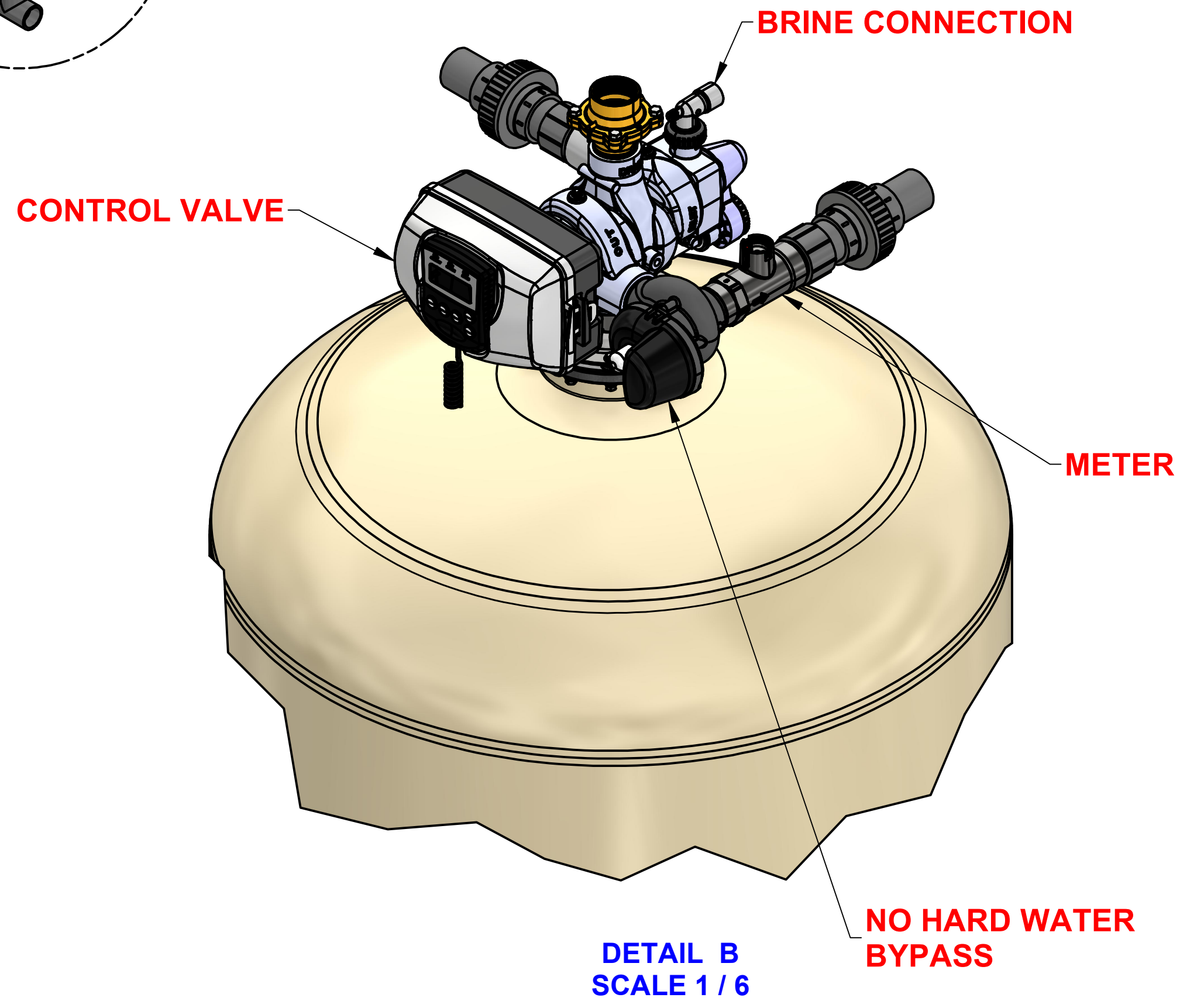
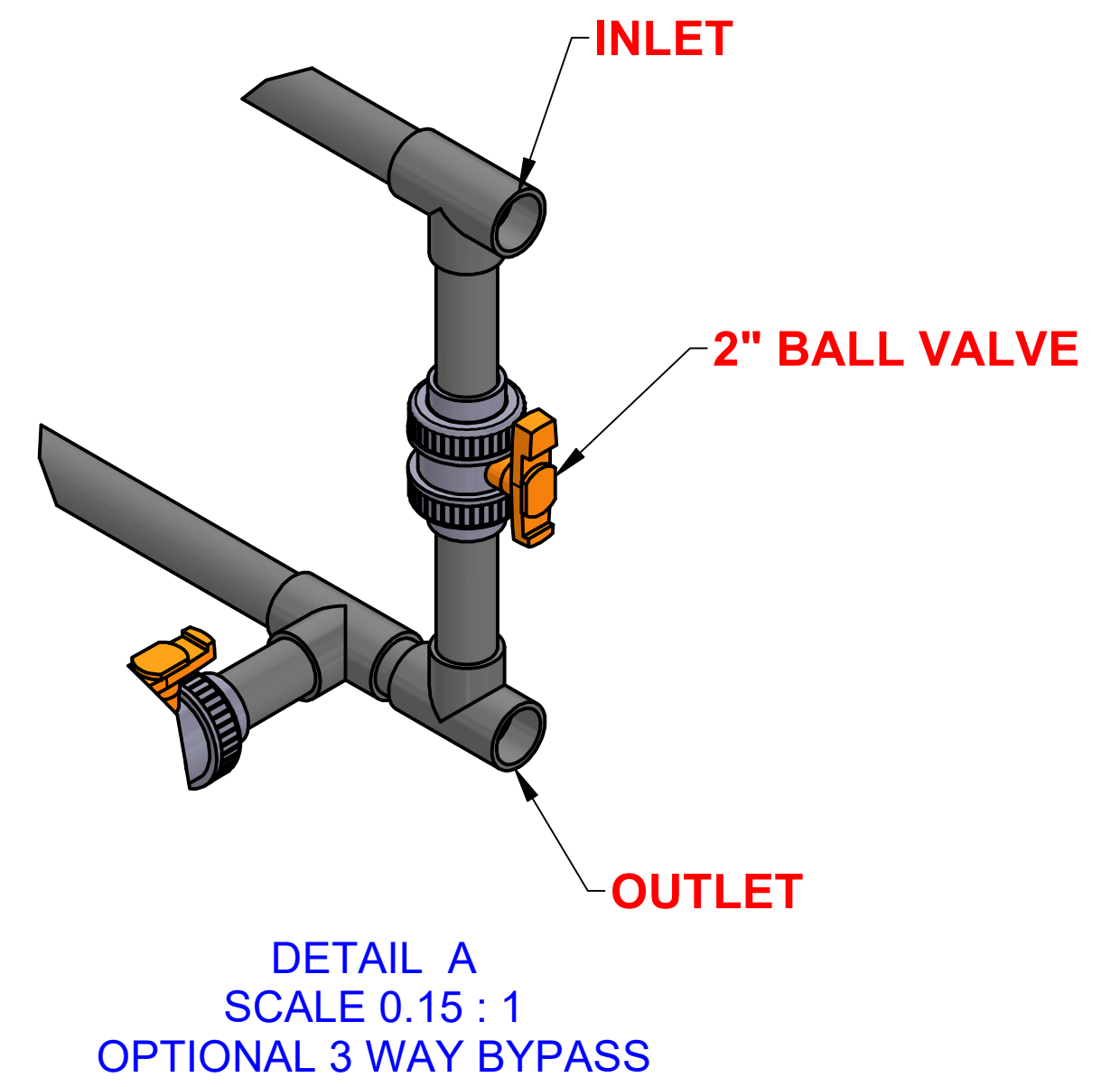
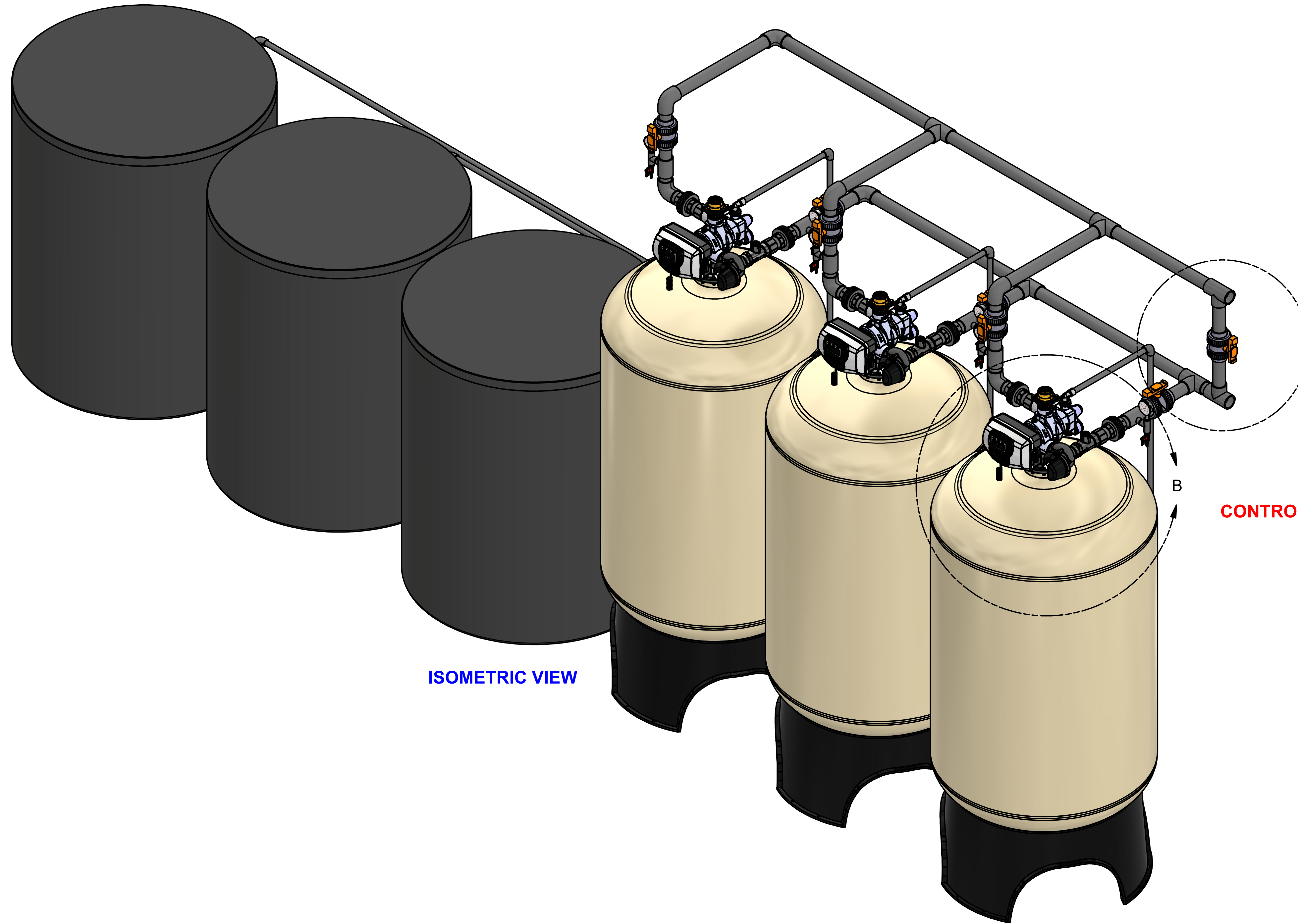

ISOMETRIC VIEW

NOTE:

1. DRAWING IS FOR REFERENCE ONLY.
2. PIPING AND INSTRUMENTATION SHOWN ARE NOT INCLUDED IN THE SCOPE.
3. RECOMMEND INSTALLING HORIZONTAL FLEX CONNECTORS ON BOTH INLET AND OUTLET FOR FRP TANK EXPANSION.
4. RECOMMEND INSTALLING VACUUM BREAKER(S) ON ALL INLET FRP TANK CONNECTIONS.
5. PROVIDE AN AIR GAP ON DRAIN LINE OF AT LEAST 4 TIMES THE DIAMETER OF THE PIPE OR FOLLOW LOCAL PLUMBING CODES.

This drawing contains information and data which is proprietary to Excalibur Water Systems Inc. This drawing, or any portion thereof, may not be reproduced, copied, or duplicated in any manner, nor used for manufacturing, without the written permission of Excalibur Water Systems Inc.

	UNLESS OTHERWISE SPECIFIED dimensions are in inches.	DRAWN CSiddarushi	2022-11-22	TITLE WATER SOFTENER 2.0" HEAVY FLOW TRIPLEX 750,000 CAPACITY
	Tolerance on: Decimals: .XXX ± .5 .XX ± 1 .X ± 2	CHECKED M. GARNER	2022-11-22	
	Angles: ± 1°	PROJECT MGR M. GARNER	2022-11-22	DRW NO. EWS SC2HF3750
		ENGINEER M. GARNER	2022-11-22	
		APPROVED M. GARNER	2022-11-22	SCALE 1/12
				SHEET 1 OF 2

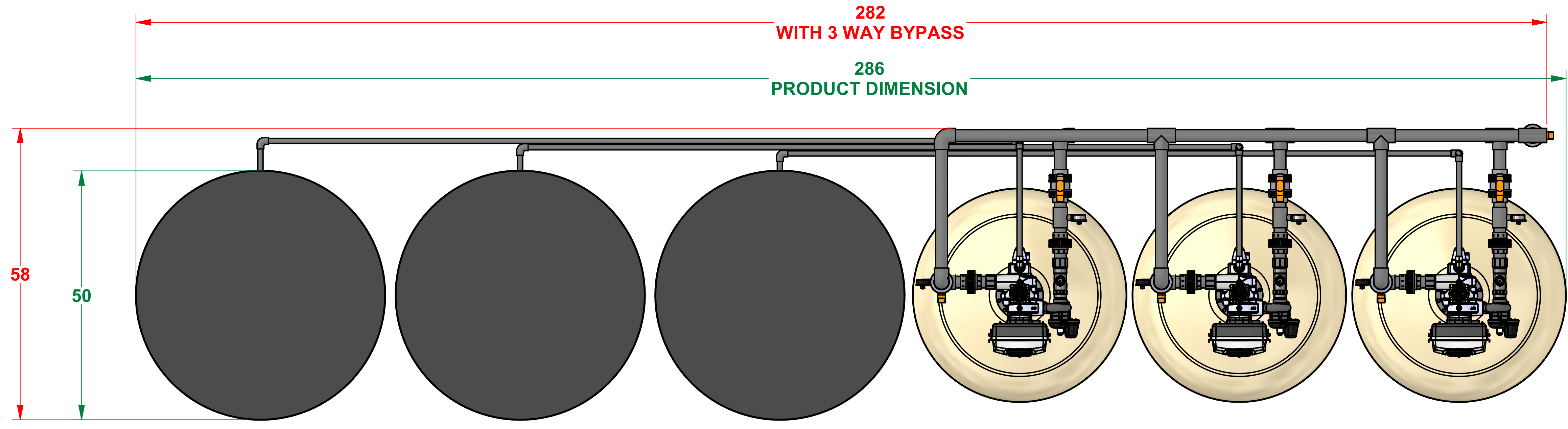

TOP VIEW

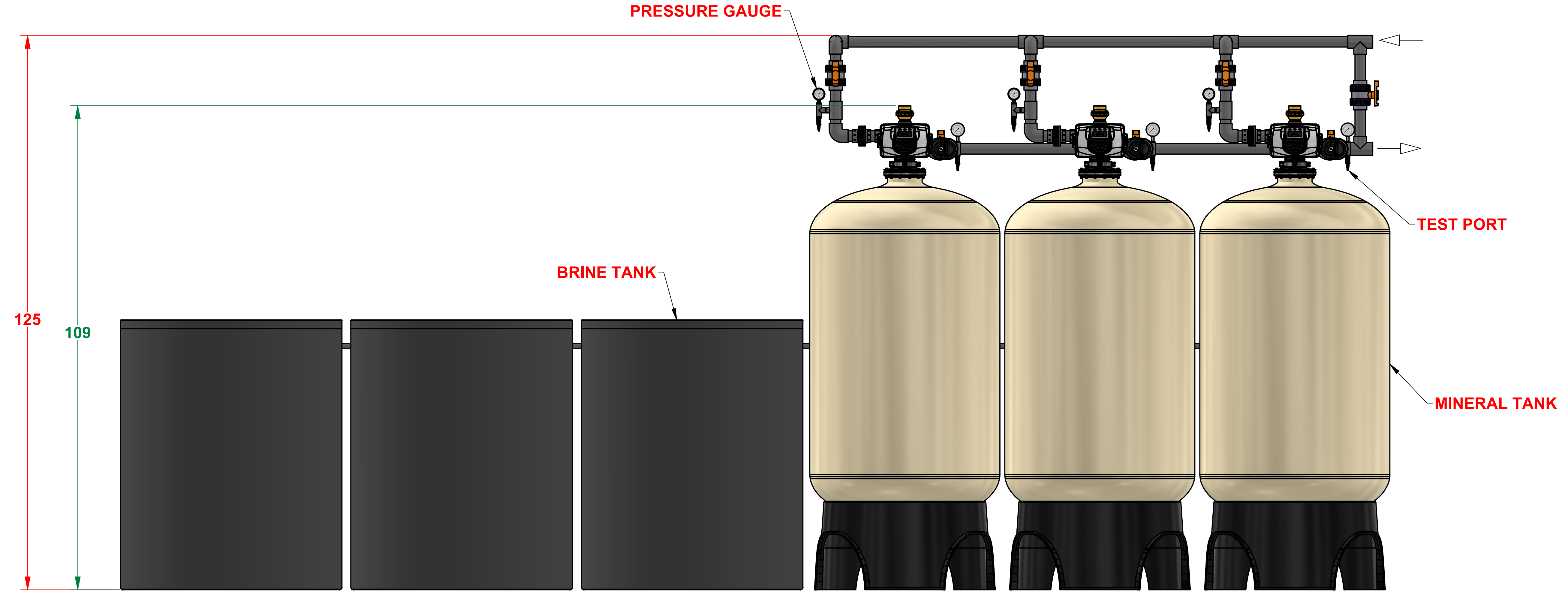

FRONT VIEW