

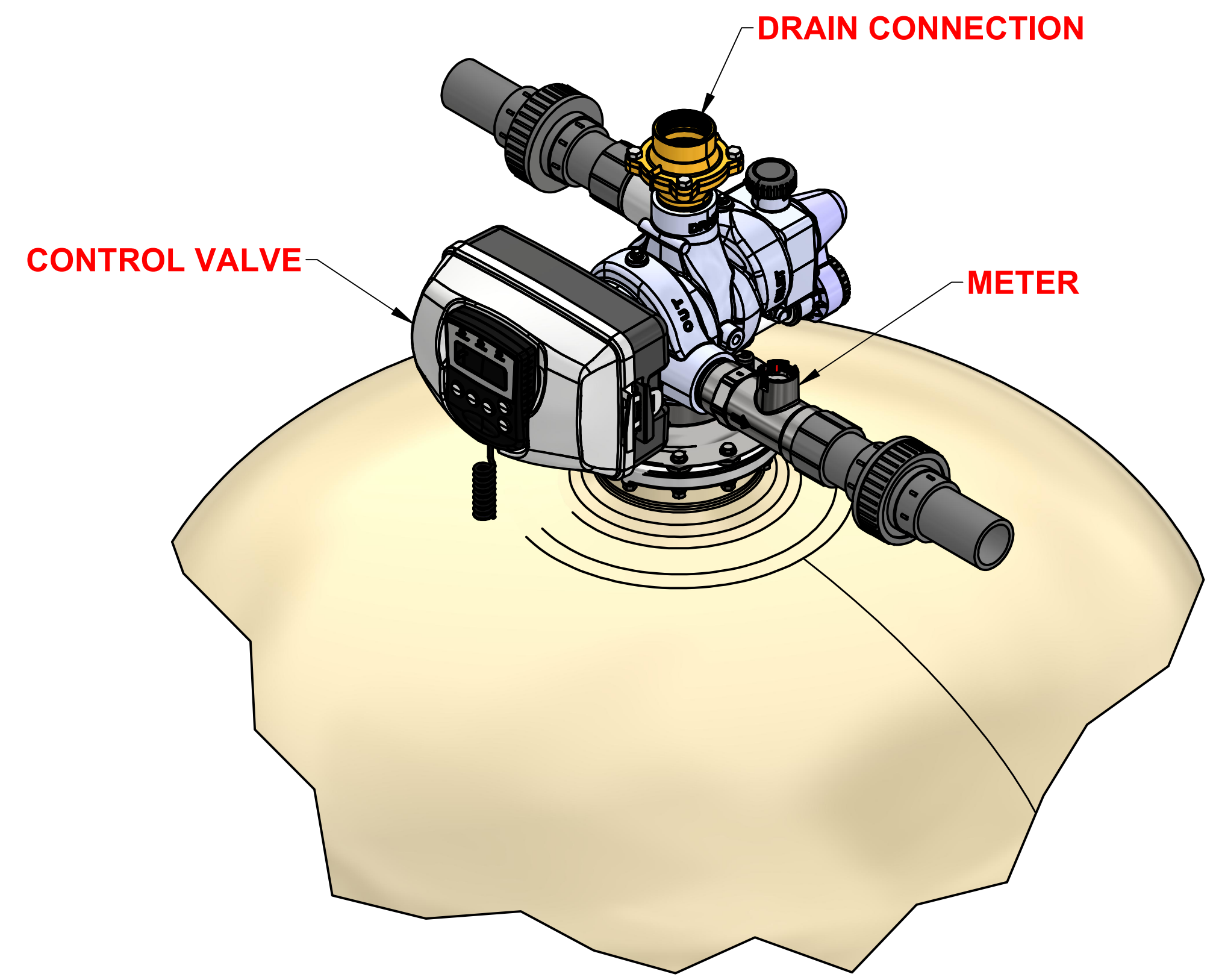

CONTROL VALVE (in)	PIPING CONNECTIONS (in)			MINERAL TANK (in)	MEDIA PER VESSEL (ft³)	FLOW RATE (gpm)						WEIGHT (lbs)		
	INLET	OUTLET	DRAIN			MIN	CHLORAMINE	TOC	CHLORINE	15psi ΔP	25psi ΔP	BACKWASH	SHIPPING	OPERATING
2.0	2.0	2.0	2.0	48 X 72	32.0	14.0	24.0	32.0	96.0	110.0	135.0	125.0	3,200	4,160

REVISION HISTORY				
REV	DESCRIPTION	DATE	DESIGNER	APPROVED
A	INITIAL RELEASE	2023-02-27	CSiddarushi	M. GARNER

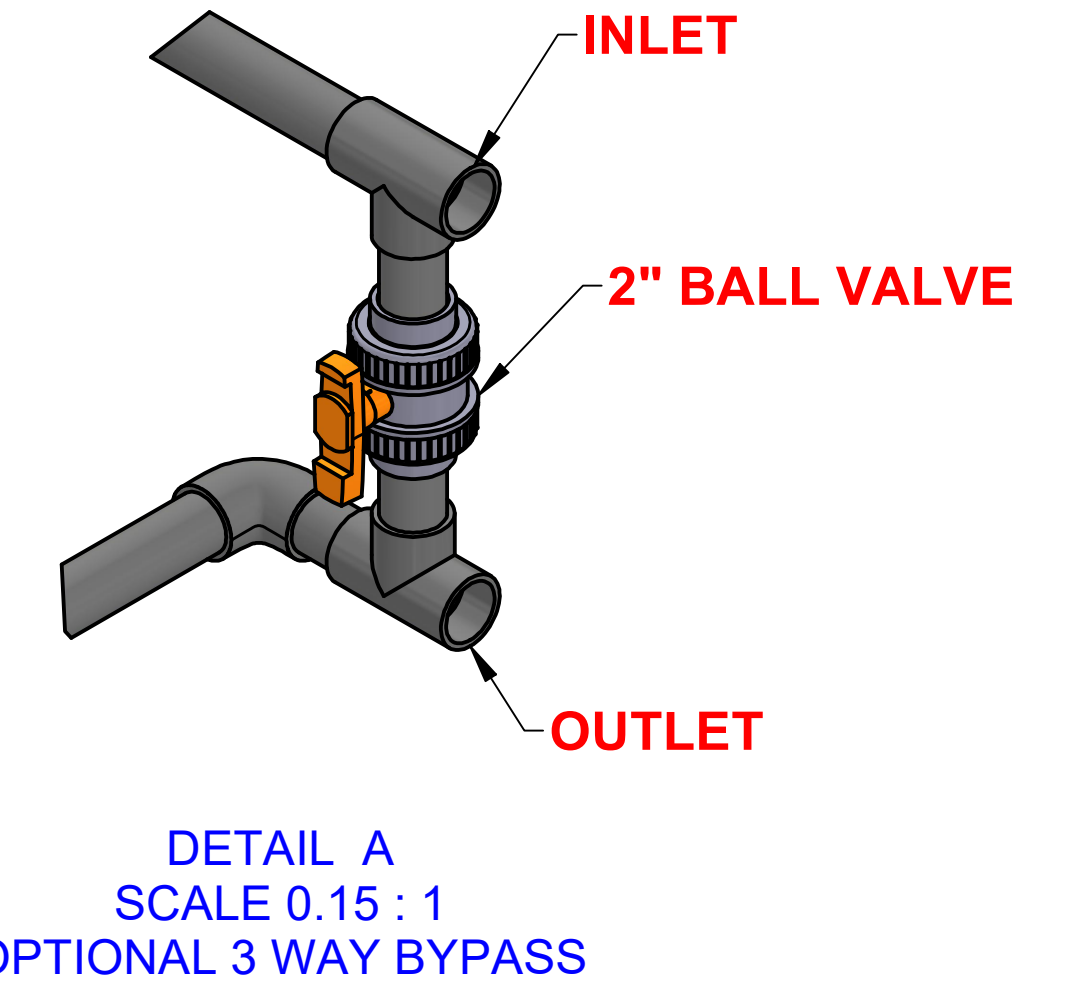
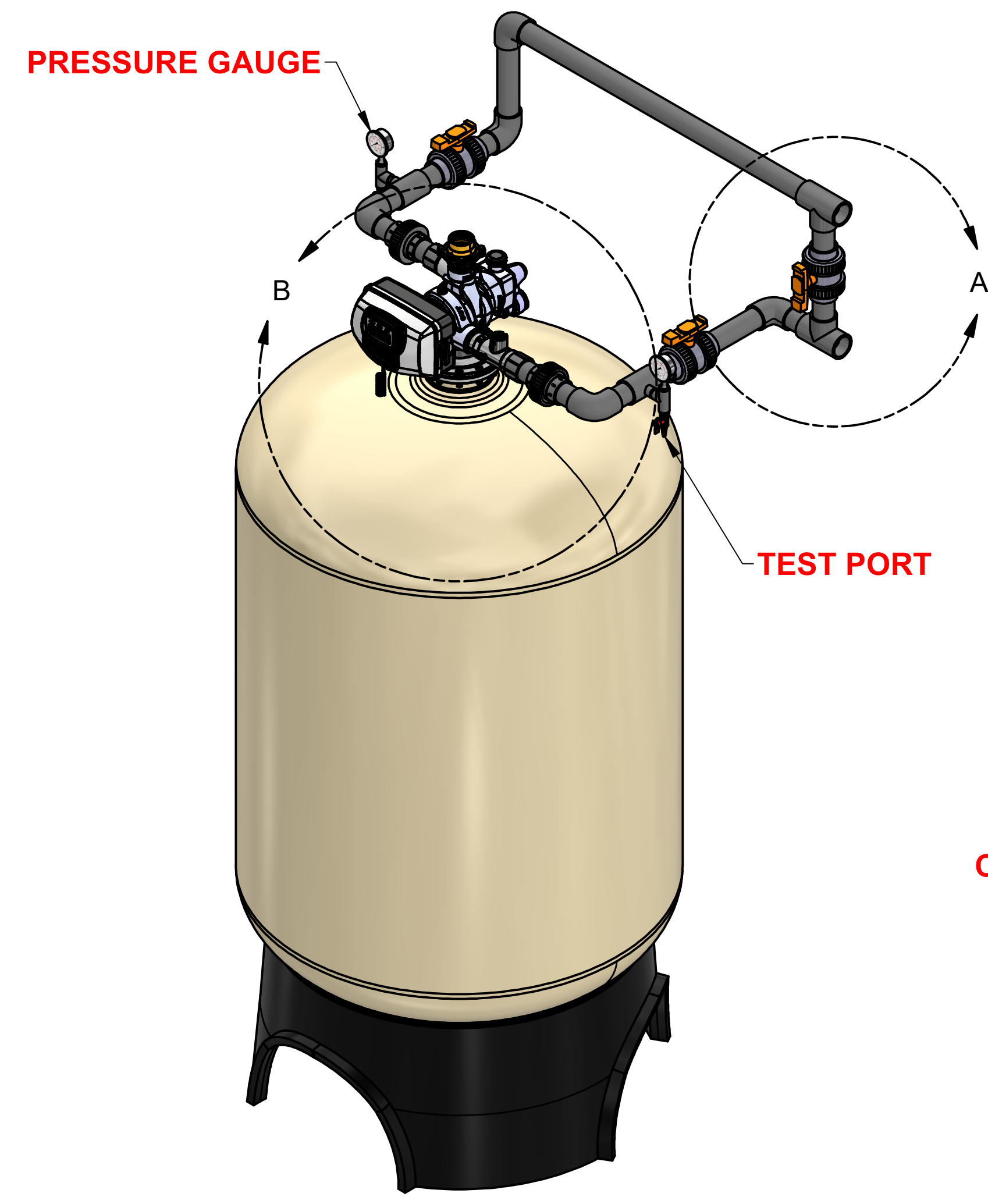
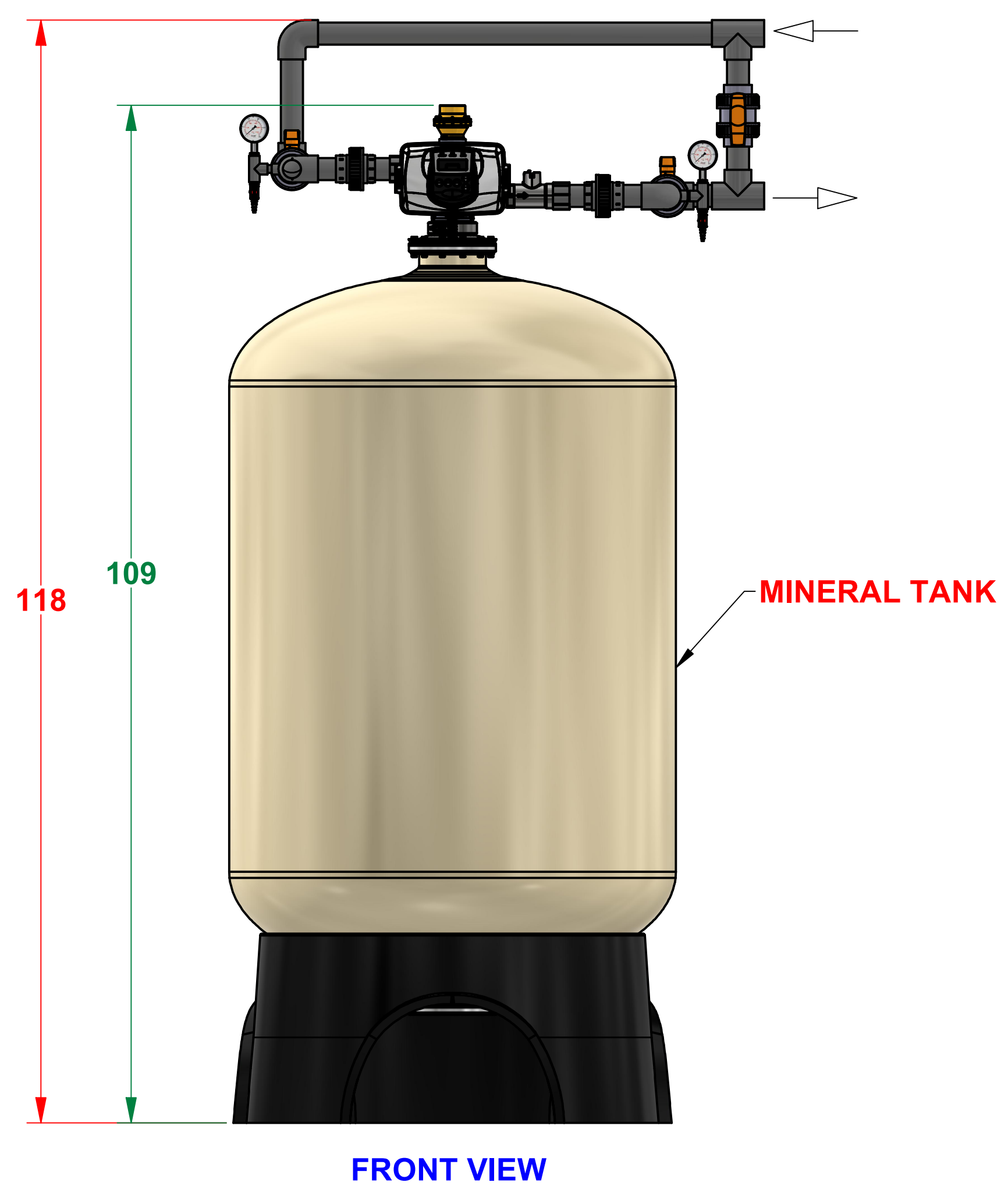
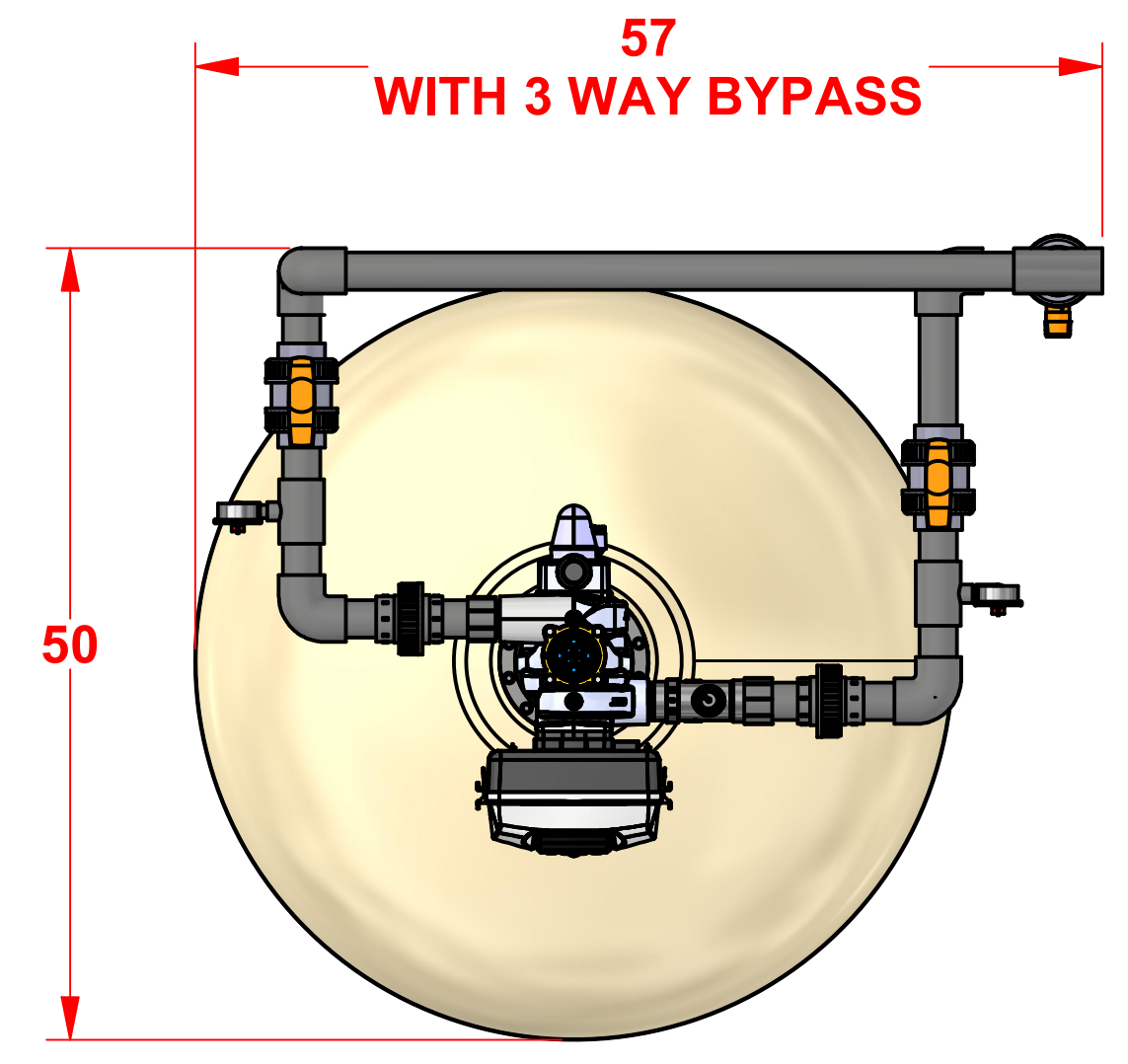

NOTE:

1. DRAWING IS FOR REFERENCE ONLY.
2. PIPING AND INSTRUMENTATION SHOWN ARE NOT INCLUDED IN THE SCOPE.
3. RECOMMEND INSTALLING HORIZONTAL FLEX CONNECTORS ON BOTH INLET AND OUTLET FOR FRP TANK EXPANSION.
4. RECOMMEND INSTALLING VACUUM BREAKER(S) ON ALL INLET FRP TANK CONNECTIONS.
5. PROVIDE AN AIR GAP ON DRAIN LINE OF AT LEAST 4 TIMES THE DIAMETER OF THE PIPE OR FOLLOW LOCAL PLUMBING CODES.

	UNLESS OTHERWISE SPECIFIED dimensions are in inches.	DRAWN CSiddarushi	2023-02-27	TITLE	FILTER CHEMICAL REMOVAL 2.0" HF SIMPLEX PROGRESSIVE 32.0ft³
	Tolerance on: Decimals .XXX = ± .5 .XX = ± 1 .X = ± 2	CHECKED M. GARNER	2023-02-27	DRW NO.	
Angles ± 1°	PROJECT MGR M. GARNER	2023-02-27	SCALE	1/12	Rev
	ELE ENGINEER M. GARNER	2023-02-27			A
	APPROVED M. GARNER	2023-02-27			
					SHEET 1 OF 1

This drawing contains information and data which is proprietary to Excalibur Water Systems Inc. This drawing, or any portion thereof, may not be reproduced, copied, or duplicated in any manner, nor used for manufacturing, without the written permission of Excalibur Water Systems Inc.